

All TEKTRONIX instruments are warranted against defective materials and workmanship for one year. Any questions with respect to the warranty should be taken up with your TEKTRONIX Field Engineer or representative.

All requests for repairs and replacement parts should be directed to the TEKTRONIX Field Office or representative in your area. This will assure you the fastest possible service. Please include the instrument Type Number or Part Number and Serial Number with all requests for parts or service.

Specifications and price change privileges reserved.

Copyright © 1972 by Tektronix, Inc., Beaverton, Oregon. Printed in the United States of America. All rights reserved. Contents of this publication may not be reproduced in any form without permission of Tektronix, Inc.

U.S.A. and foreign TEKTRONIX products covered by U.S. and foreign patents and/or patents pending.

TEKTRONIX is a registered trademark of Tektronix, Inc.

7904 OSCILLOSCOPE OPERATORS

Serial Number _____

TABLE OF CONTENTS

SECTION 1	SPECIFICATION	Page	SECTION 2	OPERATING INSTRUCTIONS	Page
	7904 Features	1-1		(cont)	
	Table 1-1 Electrical Characteristics			Operating Checkout	
	Vertical Deflection System	1-1		General	2-7
	Triggering	1-2		Set-Up Information	2-8
	Horizontal Deflection System	1-2		Display Focus	2-8
	Calibrator	1-3		Trace Alignment	2-8
	External Z-Axis Input	1-4		Graticule Illumination	2-8
	Signal Outputs	1-5		Control Illumination	2-8
	Character Generator	1-6		Vertical Deflection System	2-9
	Cathode-Ray Tube (CRT)	1-6		Horizontal Deflection System	2-9
	Power Supply	1-7		Triggering	2-10
	Table 1-2 Environmental			Readout	2-11
	Characteristics	1-8		Beam Finder	2-11
	Table 1-3 Physical Characteristics	1-8		Calibrator	2-11
	Standard Accessories	1-8		Z-Axis Input	2-12
	Instrument Options			Simplified Operating Instructions	2-12
	General	1-8		General Operating Information	
	Option 1	1-9		Intensity Controls	2-16
	Option 2	1-9		Display Focus	2-17
	Option 3	1-9		Astigmatism Adjustment	2-17
	Option 4	1-9		Trace Alignment Adjustment	2-17
	System Specifications	1-10		Graticule	2-17
				Light Filter	2-17
				Beam Finder	2-18
				Control Illumination	2-18
				Readout	2-18
				Remote Readout	2-19
				Display Photography	2-20
				Vertical and Horizontal Mode	
				Switch Logic	2-20
				Vertical Mode	2-21
				Horizontal Mode	2-22
				Vertical Trace Separation	2-23
				Trigger Source	2-23
				X-Y Operation	2-24
				Intensity Modulation	2-25
				Raster Display	2-25
				Calibrator	2-25
				Signal Outputs	2-26
				Probe Power Connectors	2-27
				Remote Connector	2-27
				Remote Single-Sweep Reset	2-27
				Applications	2-28
SECTION 2	OPERATING INSTRUCTIONS				
	General	2-1			
	Preliminary Information				
	Operating Voltage	2-1			
	Operating Temperature	2-2			
	Operating Position	2-2			
	Display Definitions	2-2			
	Plug-In Units				
	General	2-3			
	Installation	2-3			
	Controls and Connectors				
	General	2-4			
	Cathode-Ray Tube (CRT)	2-4			
	Mode Selectors	2-6			
	Calibrator	2-6			
	Outputs	2-7			
	Power	2-7			
	Rear Panel	2-7			

SPECIFICATION

7904 Features

The Tektronix 7904 Oscilloscope is a solid-state, high-performance instrument designed for general-purpose applications. This instrument accepts Tektronix 7-series plug-in units to form a complete measurement system. The flexibility of this plug-in feature and the variety of plug-in units available allow the system to be used for many measurement applications.

The 7904 has four plug-in compartments. The left pair of plug-ins is connected to the vertical system. The right pair is connected to the horizontal deflection system. Electronic switching between the plug-ins connected to each deflection system allows a dual-trace vertical display and/or a dual-sweep horizontal display. This instrument features regulated DC power supplies to assure that performance is not affected by variations in line voltage and frequency, or by changes in load due to the varying power requirements of the plug-in units. Maximum power consumption of the 7904 is about 190 watts (60 hertz, 115-volt line).

The 7904 features a CRT with small spot size and high writing rate. Graticule area is 8 X 10 centimeters.

Additionally, the instrument includes a readout system providing CRT display of alpha-numeric information from the plug-ins, including deflection factor, sweep rate, and other encoded parameters.

This instrument will meet the electrical characteristics listed in the Performance Requirement column of Table 1-1 following complete calibration as given in the Service manual. The following electrical characteristics apply over an ambient temperature range of 0°C to +50°C, except as otherwise indicated. Warmup time for given accuracy is 20 minutes.

NOTE

Many of the measurement capabilities of this instrument are determined by the choice of plug-in units. The following characteristics apply to the 7904 Oscilloscope only. See the System Specifications later in this section for characteristics of the complete system.

TABLE 1-1
ELECTRICAL

Characteristic	Performance Requirement	Supplemental Information
VERTICAL DEFLECTION SYSTEM		
Deflection Factor	Compatible with all 7-series plug-in units.	
Accuracy	Less than 1% difference between vertical compartments.	
Low-frequency linearity	0.1 division or less compression or expansion of a center-screen two-division signal when positioned anywhere vertically within the graticule area.	
Bandwidth	Varies with amplifier plug-in selected. See System Specifications.	
With 7A19 Amplifier		
+20°C to +30°C	DC to at least 500 megahertz.	
0°C to +50°C		DC to at least 400 megahertz.

TABLE 1-1 (cont)

Characteristic	Performance Requirement	Supplemental Information
Isolation Between Vertical Compartments (eight-division reference signal)	At least 100:1 from DC to 250 megahertz; decreasing to at least 40:1 from 250 megahertz to 500 megahertz.	
Chopped Mode		
Repetition rate		One megahertz \pm 20%.
Time segment from each compartment		0.4 to 0.6 microsecond.
Delay Line		Permits viewing of leading edge of triggering signal.
Difference in Delay Between Compartments		0.1 nanosecond or less.
Vertical Display Modes	<p>LEFT: Left vertical unit only.</p> <p>ALT: Dual-trace, alternates between vertical units.</p> <p>ADD: Added algebraically.</p> <p>CHOP: Dual-trace, chopped between vertical units.</p> <p>RIGHT: Right vertical unit only.</p>	Selected by front-panel VERTICAL MODE switch.
Trace Separation Range for Dual-Sweep Modes		B trace can be positioned approximately +4 and -4 divisions from the A trace.

TRIGGERING

Trigger Source	<p>VERT MODE: Determined by vertical mode.</p> <p>LEFT VERT: From left vertical unit only.</p> <p>RIGHT VERT: From right vertical unit only.</p>	Selected by front-panel A TRIGGER SOURCE and B TRIGGER SOURCE switches. VERT MODE position automatically provides optimum trigger source for each vertical display mode.
----------------	--	--

HORIZONTAL DEFLECTION SYSTEM

Deflection Factor	Compatible with all 7-series plug-in units.	
Deflection Accuracy	Less than 1% difference between compartments.	
DC Linearity	0.1 division or less compression or expansion of a center-screen two-division signal positioned anywhere horizontally within the graticule area.	

TABLE 1-1 (cont)

Characteristic	Performance Requirement	Supplemental Information
Fastest Calibrated Sweep Rate	0.5 nanosecond/division.	With 7B90-series time-base unit only. Other 7B-series units are uncalibrated for first 60 nanoseconds of sweep time when used with 7904.
Horizontal Display Modes	A: A horizontal unit only. ALT: Dual-sweep, alternates between horizontal units. CHOP: Dual-sweep, chopped between horizontal units. B: B horizontal unit only.	Selected by front-panel HORIZONTAL MODE switch.
Phase Shift Between Vertical and Horizontal Deflection Systems		
Without phase correction	2° or less from DC to at least 35 kilohertz.	
With phase correction	Adjustable to less than 2° from DC to one megahertz.	
Chopped Mode		
Repetition rate		200 kilohertz ±20%.
Time segment from each compartment		2.0 to 3.0 microseconds.

CALIBRATOR

Wave Shape	Square wave and DC.	
Polarity	Positive-going with base-line at zero volts.	
Output Voltage		Selected by front-panel CALIBRATOR switch.
Open circuit	4 mV, 40 mV, 0.4 V, 4 V, 40 V.	
Into 50 ohms	2 mV, 20 mV, 0.2 V, 0.4 V.	
Output Current	40 milliamperes through front-panel current loop.	
Amplitude Accuracy (Voltage and Current)		
+15°C to +35°C	Within 1%.	
0°C to +50°C	Within 2%.	

TABLE 1-1 (cont)

Characteristic	Performance Requirement	Supplemental Information
Repetition Rates	One kilohertz. One-half repetition rate of B Sweep gate. DC.	Selected by front-panel RATE switch.
One-Kilohertz Accuracy (Voltage and Current)		
+15°C to +35°C	Within 0.25%.	
0°C to +50°C	Within 0.5%.	
Duty Cycle	50% within 0.1%.	
Risetime and Faltime		
4 mV through 4 V and 40 mA	Less than 0.25 microsecond.	
40 V	Less than two microseconds with 10 pF load.	

EXTERNAL Z-AXIS INPUT

Sensitivity	Two volts peak-to-peak provides trace modulation over full intensity range.	Approximately zero-volt input produces no intensity change.
Polarity of Operation	Positive-going signal decreases trace intensity; negative-going signal increases trace intensity.	
Intensity Circuit Pulse Performance (Between Rear-Panel Connector and CRT)		
Low-frequency limit		DC
Response to negative-going input		Approximately 10 nanoseconds.
Response to positive-going input		Approximately 20 nanoseconds.
Propagation delay		Approximately 25 nanoseconds.
Recovery time in response to positive input step		Approximately 50 nanoseconds.
Recovery time in response to negative input step		Approximately zero nanoseconds.
Input Resistance at DC		500 ohms ±10%.
Maximum Safe Input Voltage		15 volts (DC + peak AC)

TABLE 1-1 (cont)

Characteristic	Performance Requirement	Supplemental Information
SIGNAL OUTPUTS		
+Sawtooth		
Source	A HORIZ time-base unit or B HORIZ time-base unit.	Selected by internal Sweep switch.
Polarity		Positive-going with baseline at zero volts within one volt (into one megohm).
Output voltage		
Rate of rise		
Into 50 ohms	50 millivolts/unit of time $\pm 15\%$. ¹	
Into one megohm	One volt/unit of time $\pm 10\%$. ¹	
Peak voltage		
Into 50 ohms	At least 500 millivolts.	
Into one megohm	At least 10 volts.	
Output resistance		950 ohms $\pm 2\%$.
+Gate		
Source	A HORIZ time-base unit. B HORIZ time-base unit. Delaying time-base unit (in either horizontal compartment).	Selected by internal Gate switch.
Polarity		Positive-going with base-line at zero volts within 0.1 volt (into one megohm).
Output voltage		
Into 50 ohms	0.5 volt within 10%.	
Into one megohm	10 volts within 10%.	
Risetime into 50 ohms		Two nanoseconds or less.
Output resistance		950 ohms $\pm 2\%$.
Vertical Signal Output		
Source	Determined by B TRIGGER SOURCE switch (see Section 2).	

¹Unit of time selected by time-base time/division up to 10 nanoseconds/division maximum.

TABLE 1-1 (cont)

Characteristic	Performance Requirement	Supplemental Information
Output voltage Into 50 ohms	25 millivolts/division of vertical deflection $\pm 25\%$.	
Into one megohm	0.5 volt/division of vertical deflection $\pm 25\%$.	
Bandwidth	Varies with amplifier plug-in unit selected; see System Specifications.	
Output resistance		950 ohms $\pm 2\%$.

CHARACTER GENERATOR

Mode	Free-run independent of sweep. Triggered at end of selected sweep. Single-shot controlled through rear-panel Remote Control Connector J90.	Selected by internal Readout Mode switch.
Word Location		See Fig. 2-6.

CATHODE-RAY TUBE (CRT)

Graticule Type	Internal, illuminated with variable edge lighting.	
Area Standard instrument	Eight divisions vertical by 10 divisions horizontal. Each division equals one centimeter.	
Option 4	Eight divisions vertical by 10 divisions horizontal. Each division equals 0.5 centimeter.	
Phosphor	P31 standard.	Others available on special order.
Beam Finder		Limits display within graticule area when actuated.

TABLE 1-1 (cont)

Characteristic	Performance Requirement	Supplemental Information	
Minimum Photographic Writing Speed with Polaroid ² Type 410 Film (without film fogging techniques) Standard instrument Tektronix C-51R camera with f1.2 lens and 1:0.5 object-to-image ratio		P31	P11
		281 centimeters/nanosecond	6.1 centimeters/nanosecond
Option 4 Tektronix C 51R camera with f1.2 lens and 1:0.5 object-to-image ratio		P31	P11
		5.0 centimeters/nanosecond	10.0 centimeters/nanosecond

POWER SUPPLY

Line Voltage Range AC, RMS		Selected by rear-panel Line Selector assembly.
115-volts nominal	90 to 132 volts.	
230-volts nominal	180 to 264 volts.	
Line Frequency		48 to 440 hertz.
Maximum Power Consumption		190 watts, 2.5 amperes at 60 hertz, 115-volt line.

²Registered trademark of the Polaroid Corporation.

TABLE 1-2
ENVIRONMENTAL CHARACTERISTICS

Characteristic	Performance
<i>NOTE</i>	
<i>This instrument will meet the electrical characteristics given in the Performance Requirement column of Table 1-1 over the following environmental limits, except as otherwise indicated.</i>	
Temperature Range	
Operating	0°C to +50°C.
Non-operating	-55°C to +75°C.
Altitude	
Operating	15,000 feet.
Non-operating	Test limit 50,000 feet.
Electro-magnetic Interference (EMI) as tested in MIL-I-6181D (when equipped with option 3 only)	
Radiated interference	Interference radiated from the instrument under test within the given limits from 150 kilohertz to 1000 megahertz.
Conducted interference	Interference conducted out of the instrument under test through the power cord within the given limits from 150 kilohertz to 25 megahertz.
Transportation (packaged instrument, without plug-ins)	Qualifies under National Safe Transit Committee test procedure 1A, Category II.

TABLE 1-3
PHYSICAL

Characteristic	Performance
Ventilation	Safe operating temperature maintained by convection cooling. Automatic resetting thermal cutout protects instrument from overheating.
Warm-up Time	20 minutes for rated accuracy.
Finish	Anodized front panel. Blue-vinyl painted aluminum cabinet.
Overall Dimensions (measured at maximum points)	
Height	13.5 inches (34.2 centimeters).
Width	12.0 inches (30.5 centimeters).
Length	23.8 inches (69.5 centimeters).
Net Weight (instrument only)	30 pounds (13.5 kilograms).

STANDARD ACCESSORIES

Standard accessories supplied with the 7904 are given in the Mechanical Parts List illustrations in the Service manual. For optional accessories available for use with this instrument, see the Tektronix, Inc. catalog.

INSTRUMENT OPTIONS

General

The following options are available for the 7904 and can be installed as part of the instrument when ordered, or they can be installed at a later time. Complete information on all options for this instrument is given in this manual. For further information on instruments options, see your Tektronix, Inc. catalog or contact your local Tektronix Field Office or representative.

Option 1

This option deletes the Readout System. Operation of the instrument is unchanged except that there is no alpha-numeric display on the CRT and the READOUT control is non-functional. The Readout System can be added at any time by ordering the CRT Readout Conversion Kit, Tektronix Part No. 040-0605-00.

Option 2

The X-Y Delay Compensation Network can be added to the instrument to equalize the signal delay between the vertical and horizontal deflection systems. When this network is installed and activated, the phase shift between the vertical and horizontal channels is adjustable to less than

2° from DC to one megahertz. This option can be added at any time by ordering the X-Y Conversion Kit, Tektronix Part No. 040-0606-00.

Option 3

With option 3 installed, the instrument will meet the EMI interference specifications given in Table 1-2. This option can be added at any time by ordering the EMI Conversion Kit, Tektronix Part No. 040-0570-00.

Option 4

This option substitutes the standard CRT with a one-half scan CRT (four by five centimeter graticule area) to provide maximum trace brightness and optimum photographic writing speed.

SYSTEM SPECIFICATIONS

Your Tektronix 7900-series oscilloscope system provides exceptional flexibility in operation with a wide choice of general and special purpose plug-in units. The type number of a particular plug-in unit identifies its usage as follows:

The first digit (7) denotes the oscilloscope system for which the plug-in unit is designed (7000-series).

The second letter describes the purpose of the plug-in unit:

- A – Amplifier unit.
- B – “Real time” time-base unit.
- D – Digital unit.
- J – Spectrum analyzer, single width.

K – Spectrum analyzer, single width.

L – Spectrum analyzer, double width.

M – Miscellaneous.

S – Sampling Unit

T – Sampling time-base unit.

The third and fourth digits of the plug-in type number are sequence numbers and do not carry any special connotation.

An “N” suffix letter added to the normal four digit type number identifies a unit not equipped with the circuitry necessary to encode data for the 7000-series readout system.

7900-SERIES OSCILLOSCOPE SYSTEM VERTICAL SPECIFICATIONS

This table lists the vertical specifications which are system dependent. For more complete specifications on plug-in units for the 7000-Series Oscilloscope System, refer to the Tektronix Catalog.

Amplifier Plug-In Unit	Probe	BW	T _r	Vertical System Deflection Factor Accuracy*			SIG OUT	
				EXT CAL 0 to 50°C	INT CAL 15 to 35°C	INT CAL 0 to 50°C	BW	T _r
7A11	Integral	250 MHz	1.4 ns	2%	3%	4%	140 MHz	2.5 ns
7A12	None	120 MHz	2.9 ns	2%	3%	4%	110 MHz	3.2 ns
	P6053	120 MHz	2.9 ns	3%	4%	5%	110 MHz	3.2 ns
7A13	None	105 MHz	3.4 ns	1.5%	2.5%	3.5%	100 MHz	3.5 ns
	P6053	105 MHz	3.4 ns	1.5%	2.5%	3.5%	100 MHz	3.5 ns
	P6055	65 MHz	5.4 ns	1.5%	2.5%	3.5%	65 MHz	5.4 ns
7A14	P6021	55 MHz	6.4 ns	2%	3%	4%	50 MHz	7.0 ns
	P6022	120 MHz	2.9 ns	2%	3%	4%	100 MHz	3.5 ns
7A15A	None	80 MHz	4.4 ns	2%	3%	4%	70 MHz	5.0 ns
	P6053	80 MHz	4.4 ns	3%	4%	5%	70 MHz	5.0 ns
7A16	None	225 MHz	1.6 ns	2%	3%	4%	140 MHz	2.5 ns
	P6053	225 MHz	1.6 ns	3%	4%	5%	140 MHz	2.5 ns
7A18	None	80 MHz	4.4 ns	2%	3%	4%	70 MHz	5.0 ns
	P6053	80 MHz	4.4 ns	3%	4%	5%	70 MHz	5.0 ns
7A19	None	500 MHz	0.8 ns	2%	3%	4%	300 MHz	1.2 ns
	P6051	450 MHz	0.9 ns	2%	3%	4%	300 MHz	1.2 ns
	P6056/P6057	500 MHz	0.8 ns	3%	4%	5%	300 MHz	1.2 ns
7A22	None or any	1.0 MHz ±10%	350 ns ±9%	2%	3%	4%	1.0 MHz ±10%	350 ns ±9%

*Deflection Factor accuracy is checked as follows:

EXT CAL 0°C to 50°C—Plug-in gain set at a temperature within 10°C of operating temperature, using an external calibrator whose accuracy is within 0.25%.

INT CAL 15°C to 35°C—Plug-in gain set while operating within a temperature range of +15°C to +35°C, using the oscilloscope calibrator.

INT CAL 0°C to 50°C—Plug-in gain set using the oscilloscope calibrator (within 10°C of the operating temperature) in a temperature range between 0°C and +50°C.

OPERATING INSTRUCTIONS

General

To effectively use the 7904, the operation and capabilities of the instrument must be known. This section describes the operation of the front- and rear-panel controls and connectors and gives basic and general operating information.

PRELIMINARY INFORMATION

Operating Voltage

WARNING

This instrument is designed for operation from a power source with its neutral at or near earth (ground) potential with a separate safety-earth conductor. It is not intended for operation from two phases of a multi-phase system, or across the legs of a single-phase, three-wire system. Operation from such ungrounded sources is unsafe.

The 7904 can be operated from either a 115-volt or a 230-volt nominal line voltage source. The Line Selector assembly on the rear panel converts this instrument from one operating voltage to the other. This assembly also includes fuses to provide protection for the line-input portion of this instrument. Use the following procedure to obtain correct instrument operation from the line voltage available.

Line Selector Switch Position	Regulating Range
115 V	90 to 132 volts
230 V	180 to 264 volts

1. Disconnect the instrument from the power source.
2. Loosen the two captive screws which hold the cover onto the selector assembly; then pull to remove the cover.
3. To convert from 115-volts to 230-volts nominal line voltage, or vice versa, pull out the Selector switch bar (see Fig. 2-1) and plug it back into the remaining holes. Change

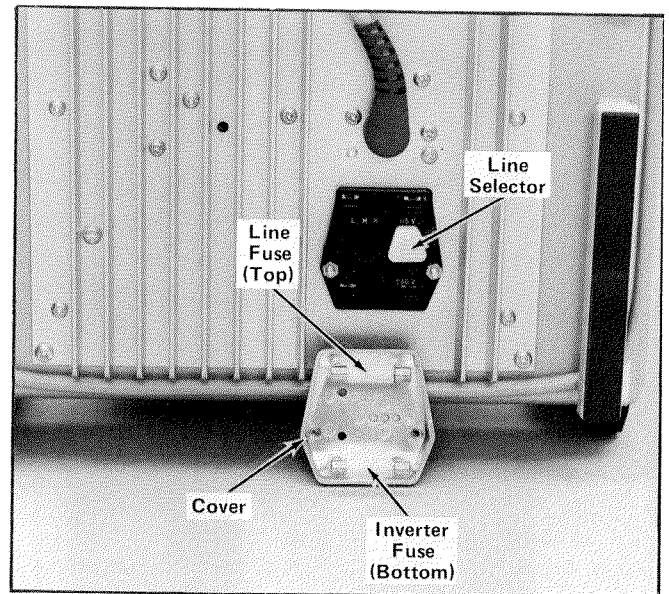

Fig. 2-1. Line Selector assembly on rear panel (shown with cover removed).

the line-cord power plug to match the power source receptacle or use a 115- to 230-volt adapter.

NOTE

Color-coding of the cord conductors is as follows (in accordance with National Electrical Code):

Line	Black
Neutral	White
Safety earth (ground)	Green with yellow stripe

4. Re-install the cover and tighten the captive screws.
5. Before applying power to the instrument, check that the indicator tab on the switch bar is protruding through the correct hole for the desired nominal line voltage.

CAUTION

This instrument may be damaged if operated with the Line Selector assembly set to incorrect positions for the line voltage applied.

Operating Instructions—7904 Operators

The 7904 is designed to be used with a three-wire AC power system. If a three- to two-wire adapter is used to connect this instrument to a two-wire AC power system, be sure to connect the ground lead of the adapter to earth (ground). Failure to complete the ground system may allow the chassis of this instrument to be elevated above ground potential and pose a shock hazard.

The feet on the rear panel provide a convenient cord wrap to store the power cord when not in use.

Operating Temperature

The 7904 can be operated where the ambient air temperature is between 0°C and +50°C. This instrument can be stored in ambient temperatures between -55°C and +75°C. After storage at temperatures beyond the operating limits, allow the chassis temperature to come within the operating limits before power is applied.

The 7904 is cooled by convection air flow through the instrument. Adequate clearance must be provided on all sides to allow heat to be dissipated from the instrument. Do not block or restrict the air flow through the holes in the cabinet. Maintain the clearance provided by the feet on the bottom and rear and allow about two inches clearance on the top and sides (more if possible).

A thermal cutout in this instrument provides thermal protection and disconnects the power from the instrument if the internal temperature exceeds a safe operating level. Power is automatically restored when the temperature returns to a safe level. Operation of this instrument in confined areas or in close proximity to heat-producing instruments may cause the thermal cutout to open more frequently.

Operating Position

A bail-type stand is mounted on the bottom of this instrument. This stand permits the 7904 to be tilted up about 10° for more convenient viewing.

DISPLAY DEFINITIONS

General

The following definitions describe the types of displays which can be obtained with a 7904 Oscilloscope System with real-time amplifiers, time-base units, or combinations of these. Use of special purpose plug-in units may result in different types of displays, which are defined in the instruction manuals for these special units. The following terminology will be used throughout this manual.

NOTE

See Simplified Operating Instructions in this section for set-up information to obtain each of the following displays.

Alternate Mode

A time-sharing method of displaying two or more signals on a single cathode-ray tube beam. Channel switching is sequential and occurs at the end of each sweep.

Chopped Mode

A time-sharing method of displaying two or more signals on a single cathode-ray tube beam. Channel switching is sequential and occurs at a rate determined by an internal clock generator (chopping rate).

Single Trace

A display of a single plot produced by one vertical signal and one sweep.

Dual Trace

A display of two plots produced by two vertical signals and one sweep. The two signals time-share a single cathode-ray tube beam.

Dual Sweep

A display of two plots produced by one vertical signal and two sweeps. Both sweeps operate independently. The two sweeps time-share a single cathode-ray tube beam.

Dual Trace—Dual Sweep

A display of four plots produced by combining two vertical signals and two sweeps. Each vertical signal is displayed against each sweep. Both sweeps operate independently.

Independent Pairs

A display of two plots produced by two vertical signals, each displayed against its own sweep (LEFT versus B; RIGHT versus A). Both sweeps operate independently. This simulates a dual-beam display for most repetitive signal combinations.

Delayed Sweep—Single Trace

A display of a single plot produced by one vertical signal and a delayed sweep. Two sweeps are used to produce this

display; the sweeps are operated with a delaying/delayed relationship where one sweep (identified as the delaying sweep) delays the start of the second sweep (identified as the delayed sweep). This display can be expanded to present two plots, produced by one vertical signal displayed against both the delaying and the delayed sweep.

Delayed Sweep—Dual Trace

A display of two plots produced by combining two vertical signals and a delayed sweep. Two sweeps are used to produce this display; the sweeps are operated with a delaying/delayed relationship. Each vertical signal is displayed against the delayed sweep. This display can be expanded to present four plots, produced by displaying both vertical signals against both the delaying and the delayed sweep.

X-Y

A plot of two variables, neither of which represents time. X refers to the horizontal axis and Y refers to the vertical axis.

PLUG-IN UNITS

General

The 7904 is designed to accept up to four Tektronix 7-series plug-in units. This plug-in feature allows a variety of display combinations and also allows selection of polarity, sensitivity, display mode, etc. to meet the measurement requirements. In addition, it allows the oscilloscope system to be expanded to meet future measurement requirements. The overall capabilities of the resultant system are in large part determined by the characteristics of the plug-in selected. A list of the currently available plug-ins for this instrument along with their major specifications, is given in Section 1. For more complete information, see the current Tektronix, Inc. catalog.

Installation

To install a plug-in unit into one of the plug-in compartments, align the slots in the top and bottom of the plug-in with the associated guide rails in the plug-in compartment. Push the plug-in unit firmly into the plug-in compartment until it locks into place. To remove a plug-in, pull the release latch on the plug-in unit to disengage it and pull the unit out of the plug-in compartment. Plug-in units can be removed or installed without turning off the instrument power.

It is not necessary that all of the plug-in compartments be filled to operate the instrument; the only plug-ins needed are those required for the measurement to be made. However, at environmental extremes, excess interference

may be radiated into and out of this instrument through the open plug-in compartments. Blank plug-in panels are available from Tektronix, Inc. to cover the unused compartments; order Tektronix Part No. 016-0155-00.

When the 7904 is calibrated in accordance with the calibration procedure given in this instruction manual, the vertical and horizontal gains are normalized. This allows calibrated plug-in units to be changed from one plug-in compartment to another without recalibration. However, the basic calibration of the individual plug-in units should be checked when they are installed in this system to verify their measurement accuracy. See the operating instructions section of the plug-in unit instruction manual for verification procedure.

The plug-in versatility of the 7904 allows a variety of display modes with many different plug-ins. Further information for obtaining these displays is given in Table 2-1, Display Combinations, later in this section. However, the following information is provided here to aid in plug-in installation.

To produce a single-trace display, install a single-channel vertical unit (or dual-channel unit set for single-channel operation) in either of the vertical compartments. For dual-trace displays, either install a dual-channel vertical unit in one of the vertical compartments or install a single-channel vertical unit in each vertical compartment. A combination of a single-channel and dual-channel vertical unit allows a three-trace display; likewise, a combination of two dual-channel vertical units allows a four-trace display.

For single time-base displays, the time-base unit can be placed in either horizontal compartment. However, for dual time-base displays, other considerations must be taken into account. If delayed-sweep operation with two time-base units is desired, the delaying time-base unit must be installed in the A HORIZ (DELAYING TIME BASE) compartment. Any compatible 7B-series unit can be used as a delayed time-base in the B HORIZ compartment. Also, delayed-sweep operation can be obtained with a dual time-base unit installed in either horizontal compartment.

In the ALT position of the VERTICAL MODE switch and ALT or CHOP position of the HORIZONTAL MODE switch, the plug-in units in the LEFT VERT and B HORIZ compartments are displayed together and the RIGHT VERT and A HORIZ plug-ins are displayed together (referred to as independent-pairs operation). Therefore, the vertical and horizontal units must be correctly mated if a special display is desired. Independent-pairs operation cannot be obtained when two time-base units are operated in a delaying-delayed sweep relationship.

Operating Instructions—7904 Operators

X-Y displays can be obtained in two ways with the 7904 system. If a 7B-series time-base unit is available which has an amplifier feature, the X signal can either be routed through one of the vertical units via the internal-trigger pickoff circuitry to the horizontal system, or connected to the external horizontal input connector of the time-base unit. Then, the vertical signal (Y) is connected to the remaining vertical unit. Also, a 7A-series amplifier plug-in can be installed in one of the horizontal compartments for X-Y operation.

Special purpose plug-ins may have specific restrictions regarding the plug-in compartments in which they can be installed. This information will be given in the instruction manuals for these plug-ins.

CONTROLS AND CONNECTORS

General

The major controls and connectors for operation of the 7904 are located on the front panel of the instrument. Several auxiliary functions are provided on the rear panel. Fig. 2-2 shows the front and rear panels of the 7904. To make full use of the capabilities of this instrument, the operator should be familiar with the function and use of each of these controls and connectors. A brief description of each control and connector is given here. More detailed operating information is given under General Operating Information.

Cathode-Ray Tube (CRT)

ASTIG	Screwdriver adjustment used in conjunction with the FOCUS control to obtain a well-defined display. Does not require re-adjustment in normal use.
A INTENSITY	Controls brightness of the trace produced by the plug-in unit in the A HORIZ (DELAYING TIME BASE) compartment. Control is in-operative when (1) the A HORIZ compartment is not selected for display by the HORIZONTAL MODE switch, (2) the A HORIZ compartment is vacant or, (3) the A plug-in does not produce a trace. Light behind the "A" of A INTENSITY indicates when the A HORIZ compartment is selected for display by the HORIZONTAL MODE switch.

FOCUS	Provides adjustment for optimum display definition.
B INTENSITY	Controls brightness of the trace produced by the plug-in unit in the B HORIZ compartment. Control is in-operative when (1) the B HORIZ compartment is not selected for display by the HORIZONTAL MODE switch, (2) the B HORIZ compartment is vacant or, (3) the B plug-in does not produce a trace. Light behind the "B" of B INTENSITY indicates when the B HORIZ compartment is selected for display by the HORIZONTAL MODE switch.
BEAM FINDER (PULL LOCK)	Compresses display within graticule area independent of display position or applied signals. Momentary actuation provided when button is pressed; display remains compressed when knob is pulled outward to lock it in the "find" position.
READOUT	Controls brightness of the readout portion of the CRT display. In the fully counterclockwise position, the Readout System is in-operative.
CONTROL ILLUM	Controls illumination level of push-button switches on 7904 and the associated plug-ins. OFF: All pushbutton lights off. A and B INTENSITY lights remain on to provide a power-on indication. LOW: All pushbuttons illuminated at low intensity. HIGH: Pushbuttons illuminated at maximum intensity.
TRACE ROTATION	Screwdriver adjustment to align trace with horizontal graticule lines.

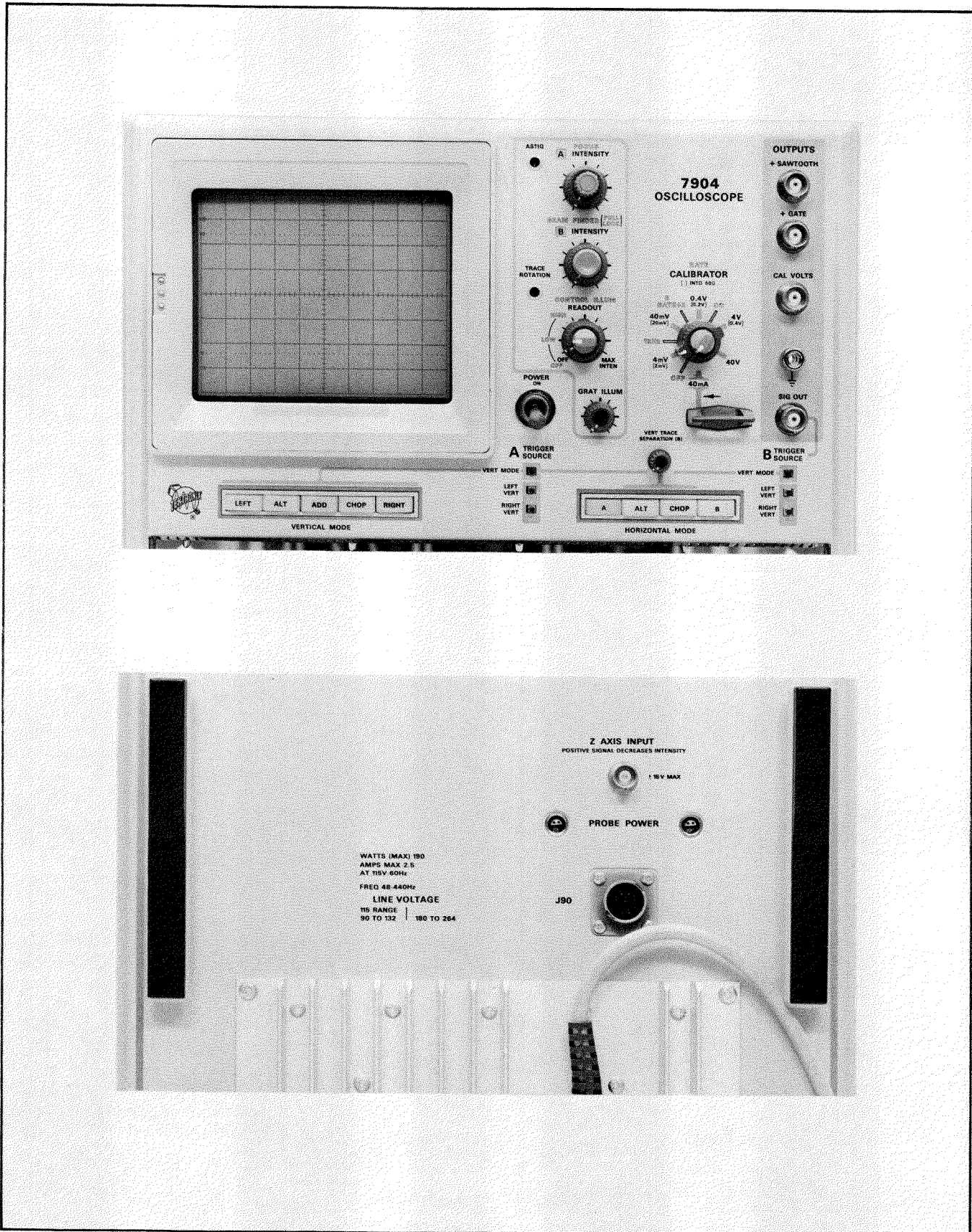

Fig. 2-2. Front- and rear-panel controls and connectors.

Operating Instructions—7904 Operators

GRAT ILLUM Controls graticule illumination.

Mode Selectors

VERTICAL MODE Selects vertical mode of operation.

LEFT: Signal from plug-in unit in LEFT VERT compartment is displayed.

ALT: Signals from plug-in units in both LEFT VERT and RIGHT VERT compartments are displayed. Display switched between vertical plug-ins after each sweep except for delayed-sweep operation. Then, the display is switched between vertical plug-ins after every second sweep. When the HORIZONTAL MODE switch is set to ALT or CHOP, independent-pairs operation is provided. (N.b., independent-pairs operation cannot be obtained if two time-base units are operated with a delaying-delayed sweep relationship.)

ADD: Signals from plug-in units in both LEFT VERT and RIGHT VERT compartments are algebraically added and the algebraic sum displayed on the CRT.

CHOP: Signals from plug-in units in both LEFT VERT and RIGHT VERT compartments are displayed. Display switched between vertical plug-ins at a one-megahertz rate.

RIGHT: Signal from plug-in unit in RIGHT VERT compartment is displayed.

A TRIGGER SOURCE Selects source of internal trigger signal for the plug-in unit in the A HORIZ compartment.

VERT MODE: Trigger signal is determined by VERTICAL MODE switch. In the ALT position of the VERTICAL MODE switch, trigger source is pre-selected by HORIZONTAL MODE switch (see Trigger Source under General Operating Information).

HORIZONTAL MODE

LEFT VERT: Trigger signal is obtained from plug-in unit in LEFT VERT compartment.

RIGHT VERT: Trigger signal is obtained from plug-in unit in RIGHT VERT compartment.

Selects horizontal mode of operation.

A: Signal from plug-in unit in the A HORIZ compartment is displayed.

ALT: Signals from plug-in units in both A HORIZ and B HORIZ compartments are displayed. Display switched between horizontal plug-ins at end of each sweep.

CHOP: Signals from plug-in units in both A HORIZ and B HORIZ compartments are displayed. Display switched between horizontal plug-ins at a 200-kilohertz repetition rate.

B: Signal from plug-in unit in the B HORIZ compartment is displayed.

B TRIGGER SOURCE

Selects source of internal trigger signal for the plug-in unit in the B HORIZ compartment. (For description of trigger source selected in each switch position, see A TRIGGER SOURCE.) Also, this switch selects the source of the vertical output signal (SIG OUT).

VERT TRACE SEPARATION (B)

Vertically positions the trace produced by the plug-in unit in the B HORIZ compartment about four divisions with respect to the trace produced by the plug-in unit in the A HORIZ compartment except for independent-pairs operation. Then, the vertical position of the B HORIZ trace is determined by the plug-in unit in the LEFT VERT compartment only.

Calibrator

CALIBRATOR

Selects amplitude of output at CAL VOLTS connector or 40 mA current through current loop. Voltage

outputs available from four millivolts to 40 volts, into high-impedance load, in decade steps, or from two millivolts to 0.4 volt into 50-ohm load (output into 50 ohms shown in brackets on panel).

RATE

Selects the mode and repetition rate of the output from the Calibrator.

OFF: Calibrator is disabled. No current through current loop and no voltage at CAL VOLTS connector.

1 kHz: Calibrator operates at one-kilohertz rate. 40-milliampere square-wave current through current loop or square-wave voltage at CAL VOLTS connector (amplitude determined by CALIBRATOR switch).

B GATE ÷2: Calibrator operates at one-half the repetition rate of the gate signal from time-base unit in the B HORIZ compartment. 40-milliampere square-wave current through current loop or square-wave voltage at CAL VOLTS connector (amplitude determined by CALIBRATOR switch).

DC: DC voltage available at CAL VOLTS connector (amplitude determined by CALIBRATOR switch), or 40-milliampere DC current through current loop.

Outputs

+ SAWTOOTH

Positive-going sample of sawtooth signal. Internal switch allows selection of sawtooth from time-base in the A HORIZ or B HORIZ compartment.

+ GATE

Positive-going signal co-incident with the respective sweep. Internal switch allows selection of one of three gate signals; A gate from time-base in A HORIZ compartment, B gate from time-base in B HORIZ compartment, or delayed

gate from delaying time-base in either horizontal compartment.

CAL VOLTS

Provides calibrator voltage output when voltage operation is selected (see CALIBRATOR).

40 mA Current Loop

Probe loop providing calibrator current output when CALIBRATOR switch is set to 40 mA position.

Ground (not labeled)

Binding post to establish common ground between the 7904 and any associated equipment.

SIG OUT

Provides output signal from the vertical plug-ins. Source of the output signal at the SIG OUT connector is selected by the B TRIGGER SOURCE switch (see Trigger Source under General Operating Information for description of signal sources available).

Power

POWER

Controls power to instrument.

Rear Panel

Line Selector (not labeled)

Switching assembly to select the nominal operating voltage (115 or 230 volts). This assembly also includes the line input fuses.

PROBE POWER

Power source for active probe systems.

Z-AXIS INPUT

Input connector for intensity modulation of the CRT display.

J90

Nine-pin connector which provides input for remote operation of the following functions: Single-sweep reset and ready indication for compatible time-base units in the A HORIZ and B HORIZ compartments, readout lockout, and single-shot readout.

OPERATING CHECKOUT

General

The following Operating Checkout procedure provides a means of verifying proper instrument operation and basic calibration without removing the covers or making internal adjustments. Screwdriver adjustments accessible from the outside of the instrument are adjusted as part of this procedure. If re-calibration of the 7904 appears to be necessary, see the Calibration procedure in Section 5 of this manual. If re-calibration of a plug-in unit is indicated, see the instruction manual for the applicable plug-in.

This procedure also demonstrates the use of the controls and connectors of the 7904. It is recommended that this procedure be followed completely for familiarization with this instrument.

Set-Up Information

1. Set the front-panel controls as follows:

A INTENSITY	Counterclockwise
FOCUS	Midrange
B INTENSITY	Counterclockwise
BEAM FINDER	Released
READOUT	OFF
CONTROL ILLUM	OFF
GRAT ILLUM	Counterclockwise
POWER	Off
CALIBRATOR	4 V
RATE	1 kHz
VERTICAL MODE	LEFT
A TRIGGER SOURCE	VERT MODE
HORIZONTAL MODE	A
VERT TRACE	Midrange
SEPARATION (B)	
B TRIGGER SOURCE	VERT MODE

2. Connect the 7904 to a power source that meets the voltage and frequency requirements of this instrument. If the available line voltage is outside the limits of the Line Selector switch setting (on rear panel), see Operating Voltage in this section.

3. Insert Tektronix 7A-series amplifier units into both the LEFT VERT and RIGHT VERT compartments. Insert Tektronix 7B-series time-base units into both the A HORIZ and B HORIZ compartments.

4. Set the POWER switch to ON. Allow several minutes warmup so the instrument reaches a normal operating temperature before proceeding.

5. Set both vertical units for a vertical deflection factor of two volts/division and center the vertical position controls. Set both vertical units for AC input coupling.

6. Set both time-base units for a sweep rate of one millisecond/division in the auto, internal trigger mode.

7. Advance the A INTENSITY control until the trace is at the desired viewing level (near midrange).

8. Connect the CAL VOLTS connector to the input of the left vertical unit with a BNC-to-BNC patch cord (supplied accessory).

Display Focus

9. Adjust the FOCUS control so the top and bottom of the displayed square wave are as thin as possible but not elongated. Set the ASTIG adjustment so the top and bottom of the displayed square wave are as thin as possible. Repeat the adjustments for best overall focus.

NOTE

This instrument contains circuitry to automatically protect the CRT phosphor against damage due to excessive CRT beam current. If the A or B INTENSITY control is set to a point where CRT phosphor damage could occur, this circuit limits the beam current to a safe level. Also, this circuit action will cause the trace to de-focus (widen) to indicate that the intensity control setting should be reduced. If the FOCUS and ASTIG adjustments cannot be made as given in step nine, decrease the setting of the A INTENSITY control and repeat the step.

Trace Alignment

10. Disconnect the input signal and position the trace with the left vertical unit position control so it coincides with the center horizontal line of the graticule. If necessary, adjust the TRACE ROTATION adjustment so the trace is parallel with the center horizontal graticule line.

Graticule Illumination

11. Rotate the GRAT ILLUM control throughout its range and notice that the graticule lines are illuminated as the control is turned clockwise (most obvious with tinted filter installed). Set control so graticule lines are illuminated as desired.

Control Illumination

12. Notice that only the light associated with the A INTENSITY control is illuminated. Sequentially press all the HORIZONTAL MODE switch buttons and notice the A or B INTENSITY lights; these lights indicate which intensity control is active. The lights also provide an indication that the POWER switch is on. Set the CONTROL ILLUM switch to the LOW position. Notice that the selected pushbuttons of the 7904 and the plug-in units are illuminated.

13. Change the CONTROL ILLUM switch to the HIGH position. Notice that the selected pushbuttons of the 7904 and the plug-in units are illuminated at maximum intensity. Return the HORIZONTAL MODE switch to A.

Vertical Deflection System

14. Connect the CAL VOLTS connector to the input connectors of both vertical units with the BNC-to-BNC jumper leads. The display amplitude should be two divisions within 0.12 division. Note the exact display amplitude.

15. Notice that the position control of only the left vertical unit has any effect on the vertical position of the displayed trace. Position the trace to the upper half of the graticule with the left vertical unit position control.

16. Press the RIGHT button of the VERTICAL MODE switch. The display amplitude should be two divisions within 0.12 division. Note the exact display amplitude.

17. Notice that the position control of only the right vertical unit has any effect on the vertical position of the displayed trace. Position the trace to the lower half of the graticule with the right vertical unit position control.

18. A correct display in both steps 14 and 16 indicates that the 7904 Vertical Deflection System and the vertical plug-in units are calibrated. Re-calibration of the 7904 is indicated when the display amplitudes noted in steps 14 and 16 are both outside the given tolerance by an equal amount in the same direction (i.e., high or low); otherwise, re-calibration of one or both vertical plug-in units is indicated.

19. Press the ALT button of the VERTICAL MODE switch. Notice that two traces are displayed on the CRT. The top trace is produced by the left vertical unit and the bottom trace is produced by the right vertical unit; the sweep for both traces is produced by the A time-base unit. Reduce the sweep rate of the A time-base unit to 50 milliseconds/division. Notice that the display alternates between the left and right vertical plug-ins after each sweep. Turn the A time-base sweep rate switch throughout its range. Notice that the display alternates between vertical units at all sweep rates.

20. Press the CHOP button of the VERTICAL MODE switch. Turn the A time-base unit sweep rate switch throughout its range. Notice that a dual-trace display is presented at all sweep rates, but unlike ALT, both vertical units are displayed on each sweep on a time-sharing basis.

Return the A time-base unit sweep rate switch to 0.5 millisecond/division.

21. Press the ADD button of the VERTICAL MODE switch. The display should be four divisions in amplitude. Notice that the position control of either vertical unit moves the display. Return the VERTICAL MODE switch to the LEFT position.

Horizontal Deflection System

22. Notice that the position control of only the A time-base unit has any effect on the horizontal position of the displayed trace. Position the start of the trace to the left graticule line with the A time-base unit position control.

23. The center eight complete cycles of the displayed waveform should occupy the center eight graticule divisions within 0.25 division. Note the exact number of horizontal divisions occupied by the center eight complete cycles of the waveform (see Fig. 2-3).

24. Press the B button of the HORIZONTAL MODE switch. Advance the B INTENSITY control until the display becomes de-focused. The de-focused display indicates that the B INTENSITY control is set too high and the CRT beam-current limiting circuit is operating to protect the CRT phosphor from damage. Reduce the setting of the B INTENSITY control to obtain a bright, well-defined display.

25. Notice that the position control of only the B time-base unit has any effect on the horizontal position of

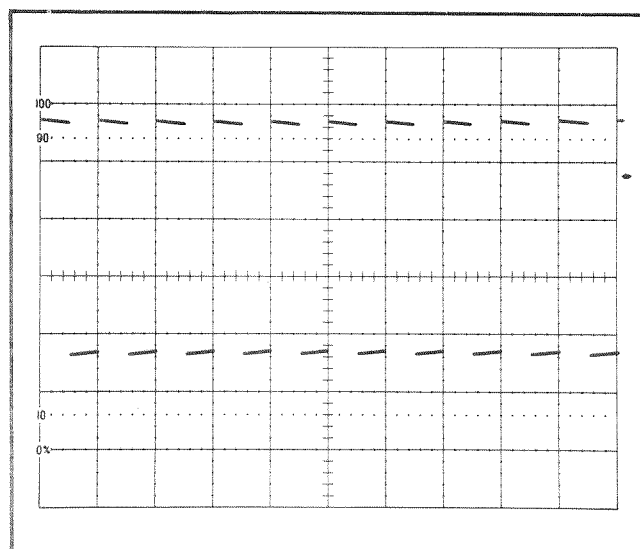

Fig. 2-3. Display showing correct calibration of 7904 Horizontal Deflection System.

Operating Instructions—7904 Operators

the displayed trace. Position the start of the trace to the left graticule line with the B time-base unit position control.

26. The center eight complete cycles of the displayed waveform should occupy the center eight graticule divisions within 0.25 division. Note the exact number of horizontal divisions occupied by the center eight complete cycles of the waveform (see Fig. 2-3).

27. A correct display in both steps 23 and 26 indicates that the 7904 Horizontal Deflection System and the time-base plug-in units are calibrated. Re-calibration of the 7904 is indicated if the waveform displays noted in both steps 23 and 26 are outside the given tolerance by an equal amount in the same direction (i.e., long or short); otherwise, recalibration of one or both plug-in units is indicated.

28. Press the ALT button of the HORIZONTAL MODE switch. Two traces should be presented on the CRT. If the display overlaps, adjust the VERT TRACE SEPARATION (B) control to position one trace to the bottom of the graticule area. Turn the sweep rate switches of both time-base units throughout their range. Notice that each time-base unit controls one of the traces independent of the other time-base unit. Also notice that when one of the time-base units is set to a slow sweep rate (below about 50 milliseconds/division), sweep alternation is evident. Only one of the traces is presented on the CRT at a time. Set the sweep rates of both time-base units to 0.5 millisecond/division. Adjust the A INTENSITY control. Notice that it changes the intensity of the trace produced by the A time-base unit only. Likewise, the B INTENSITY control changes the intensity of the trace produced by the B time-base unit only. Return both intensity controls to the desired level.

29. Press the CHOP button of the HORIZONTAL MODE switch. Notice that two traces are shown on the CRT in a manner similar to the ALT display. Turn the sweep rate switches of both time-base units throughout their range. Notice that two traces are displayed on the CRT at all sweep rates. Also notice that when both time-base units are set to a slow sweep rate (50 milliseconds/division or slower), both traces are visible on the CRT at the same time. Return the sweep rate switches of both time-base units to 0.5 millisecond/division.

30. Set the CALIBRATOR switch to 0.4 V. Press the CHOP button of the VERTICAL MODE switch. Four traces should be displayed on the CRT. If not, adjust the position controls of the vertical units and the VERT TRACE SEPARATION (B) control to position the four traces onto the viewing area. Adjust the position controls of the plug-in units to identify which traces are produced from

each of the plug-in units (if vertical units have the identify feature, it can be used to identify the traces). Also, set one of the time-base units to a sweep rate of one millisecond/division. Notice that the vertical deflection produced by the left vertical unit is displayed at the sweep rate of both the A and B time-base units and that the vertical deflection produced by the right vertical plug-in unit is also displayed at the sweep rate of both time-base units.

31. Press the ALT button of the HORIZONTAL MODE switch. Notice that the display is very similar to the display obtained in the previous step. The main difference in this display is that the sweeps are produced alternately by the time-base units (noticeable only at slow sweep rates).

32. Press the ALT button of the VERTICAL MODE switch. Set the CALIBRATOR switch to 4 V. Notice that only two traces are displayed on the CRT. Also notice that one of the traces is produced by the left vertical unit at the sweep rate of the B time-base unit and the other trace is produced by the right vertical unit at sweep rate of the A time-base unit. This feature is called independent-pairs operation and is obtained only when the VERTICAL MODE switch is in the ALT position and the HORIZONTAL MODE switch is in either the ALT or the CHOP position.

Triggering

33. Press the LEFT button of the VERTICAL MODE switch and the A button of the HORIZONTAL MODE switch. Center the display on the CRT with the left vertical unit position control. Disconnect the input signal from the right vertical unit input connector. Sequentially press all of the VERTICAL MODE switch buttons. Notice that a stable display is obtained in all positions of the VERTICAL MODE switch (straight line in RIGHT position). Also notice that in addition to the VERT MODE pushbutton of the A TRIGGER SOURCE switch, the RIGHT VERT or LEFT VERT (or both) pushbuttons are illuminated to indicate the trigger signal source for each VERTICAL MODE switch setting.

34. Press the LEFT VERT button of the A TRIGGER SOURCE switch. Again, sequentially press all of the VERTICAL MODE buttons. Notice that the display is again stable in all positions, as in the previous step.

35. Press the RIGHT VERT button of the A TRIGGER SOURCE switch. Sequentially press all the VERTICAL MODE switch buttons and notice that a stable display cannot be obtained in any position. This is because there is no input signal connected to the right vertical unit. Return the A TRIGGER SOURCE switch to VERT MODE.

36. The B TRIGGER SOURCE switch operates in a similar manner to the A TRIGGER SOURCE switch when the B time-base unit is selected for display. Return the B TRIGGER SOURCE switch to VERT MODE.

37. Press the ALT button of the VERTICAL MODE switch. Notice that all the A and B TRIGGER SOURCE pushbuttons are illuminated. This indicates that the internal trigger signals are being obtained alternately from the LEFT VERT and RIGHT VERT compartments.

38. Press the ALT or CHOP button of the HORIZONTAL MODE switch. Notice that this is the same display obtained in step 32 (independent-pairs operation). Also, notice that the VERT MODE and RIGHT VERT pushbuttons of the A TRIGGER SOURCE switch and the VERT MODE and LEFT VERT pushbuttons of the B TRIGGER SOURCE switch are illuminated. This indicates the true trigger source for both time-base units for independent-pairs operation.

Readout

NOTE

The following three steps apply only to instruments equipped with a Readout System.

39. Turn the READOUT control clockwise until an alphanumeric display is visible within the top or bottom division of the CRT. Change the deflection factor of the vertical unit that is selected for display. Notice that the readout portion of the display changes as the deflection factor is changed. Likewise, change the sweep rate of the time-base unit which is selected for display. Notice that the readout display for the time-base unit changes also as the sweep rate is changed.

40. Set the time-base unit for magnified operation. Notice that the readout display changes to indicate the correct magnified sweep rate. If a readout-coded 10X probe is available for use with the vertical unit, install it on the input connector of the right vertical plug-in unit. Notice that the deflection factor indicated by the readout is increased by 10 times when the probe is added. Return the time-base unit to normal sweep operation and disconnect the probe.

41. Sequentially press all of the VERTICAL MODE switch buttons and the HORIZONTAL MODE buttons. Notice that the readout from a particular plug-in occupies a specific location on the display area. If either of the vertical plug-in units is a dual-trace unit, notice that the readout for

channel 2 appears within the lower division of the CRT. Return the VERTICAL MODE switch to LEFT VERT.

Beam Finder

42. Set the deflection factor of the left vertical plug-in to 0.1 volt/division. Notice that a square-wave display is not visible since the deflection exceeds the scan area of the CRT.

43. Press the BEAM FINDER button. Notice that the display is returned to the viewing area in compressed form. Release the BEAM FINDER switch and notice that the display again disappears from the viewing area. Pull the BEAM FINDER outward so it locks in the "find" position. Notice that the display is again returned to the viewing area in compressed form, but that in this position it remains on the viewing area as long as the BEAM FINDER switch is locked in the outward position.

44. With the BEAM FINDER switch locked in the outward position, increase the vertical unit deflection factor until the display is reduced to about two divisions vertically. Adjust the position control of the displayed vertical unit to position the compressed display about the center of the graticule. Press the BEAM FINDER switch in and release. Notice that the display remains within the viewing area.

Calibrator

45. Set the RATE switch to the B GATE $\div 2$ position. Press the A button of the HORIZONTAL MODE switch and set the B time-base unit for free-running operation (auto-triggering with level control set so unit is not triggered). Change the sweep rate of the B time-base unit and notice that the repetition rate of the displayed signal changes as the sweep rate is changed. The repetition rate of the displayed signal is one-half the repetition rate of the gate signal produced by the B time-base unit (duration of one cycle of Calibrator waveform equals approximately 20 times the setting of the B sweep rate switch). Also notice that the amplitude of the square wave is adjustable with the CALIBRATOR switch.

46. Set the RATE switch to DC. Establish a ground reference level on the CRT (such as center horizontal line of graticule). Set the vertical unit for DC input coupling. Notice that the display is a straight line deflected from the ground reference line by the amount selected by the CALIBRATOR switch.

47. If a current-probe amplifier plug-in is available, the current function of the Calibrator can be demonstrated.

Operating Instructions—7904 Operators

Install the current-probe amplifier plug-in unit in the 7904 and press the VERTICAL MODE button which will display this unit. Set the RATE switch to the 1 kHz position and the CALIBRATOR switch to the 40 mA position. Connect the current probe to the 40 mA current loop (observe current direction shown by arrow). Set the deflection factor of the current-probe amplifier to display several divisions of the calibrator waveform. Set the RATE switch to the B GATE $\div 2$ position. Notice that the display is the same amplitude as obtained previously, but that the repetition rate is variable with the B time-base unit sweep rate switch. Change the RATE switch to the DC position. Notice that there is no deflection on the CRT. This is because the DC current function can be demonstrated only with a current-probe that is sensitive to DC current.

Z-Axis Input

48. If an external signal is available (two volts peak-to-peak minimum), the function of the Z-AXIS INPUT can be demonstrated. Remove the BNC cap from the Z-AXIS INPUT connector (on rear panel). Connect the external signal to both the input connector of the displayed vertical unit and the Z-AXIS INPUT connector. Set the sweep rate of the displayed time-base unit to display about five cycles of the waveform. Adjust the amplitude of the signal generator until intensity modulation is visible on the display (change the vertical unit deflection factor as necessary to produce an on-screen display). The positive peaks of the waveform should be blanked out and the negative peaks intensified. Notice that the setting of the intensity controls determines the amount of intensity modulation that is visible. Replace the BNC cap on the Z-AXIS INPUT connector.

49. This completes the Operating Checkout procedure for the 7904. Instrument operations not explained here, or operations which need further explanation are discussed under General Operating Information.

SIMPLIFIED OPERATING INSTRUCTIONS

General

The following information is provided to aid in quickly obtaining the correct setting for the 7904 controls to present a display. The operator should be familiar with the complete function and operation of this instrument as described in this section before using this procedure. For detailed operating information for the plug-in units, see the instruction manuals for the applicable units.

Single-Trace Display

The following procedure will provide a display of a single-trace vertical unit against one time-base unit. For

simplicity of explanation, the vertical unit is installed in the LEFT VERT compartment and the time-base unit is installed in the A HORIZ compartment. Other compartments can be used if the following procedure is changed accordingly.

1. Install a 7A-series amplifier unit in the LEFT VERT compartment.

2. Press the LEFT button of the VERTICAL MODE switch.

3. Install a 7B-series time-base unit in the A HORIZ compartment.

4. Press the A button of the HORIZONTAL MODE switch.

5. Press the VERT MODE button of the A TRIGGER SOURCE switch.

6. Set the POWER switch to ON. Allow several minutes warmup.

7. Connect the signal to the input connector of the vertical unit.

8. Set the vertical unit for AC input coupling and calibrated deflection factors.

9. Set the time-base unit for auto mode, internal triggering at a calibrated sweep rate of one millisecond/division.

10. Advance the A INTENSITY control until a display is visible (if display is not visible with A INTENSITY at about midrange, press BEAM FINDER switch and adjust the vertical deflection factor until the display is reduced in size vertically; then center compressed display with vertical and horizontal position controls; release BEAM FINDER). Adjust the FOCUS control for a well-defined display.

11. Set the vertical deflection factor and vertical position control for a display which remains within the graticule area vertically.

12. If necessary, set the time-base triggering controls for a stable display.

13. Adjust the time-base position control so the display begins at the farthest left vertical line of the graticule. Set the time-base sweep rate to display the desired number of cycles.

Dual-Trace Display

The following procedure will provide a display of two single-trace vertical units against one time-base unit.

1. Install 7A-series amplifier units in both vertical plug-in compartments.

2. Press the LEFT button of the VERTICAL MODE switch.

3. Install a 7B-series time-base unit in the A HORIZ compartment.

4. Press the A button of the HORIZONTAL MODE switch.

5. Press the VERT MODE button of the A TRIGGER SOURCE switch.

6. Set the POWER switch to ON. Allow several minutes warmup.

7. Connect the signals to the input connectors of the vertical units.

8. Set the vertical units for AC input coupling and calibrated deflection factors.

9. Set the time-base unit for auto mode, internal triggering at a sweep rate of one millisecond/division.

10. Advance the A INTENSITY control until a display is visible (if display is not visible with A INTENSITY at midrange, press BEAM FINDER switch and adjust vertical deflection factor until display is reduced in size vertically; then center compressed display with vertical and horizontal position controls; release BEAM FINDER). Set the FOCUS control for a well-defined display.

11. Set the left vertical unit deflection factor for a display about four divisions in amplitude. Adjust the vertical position control to move this display to the top of the graticule area.

12. Press the RIGHT button of the VERTICAL MODE switch.

13. Set the right vertical unit deflection factor for a display which is about four divisions in amplitude (if display cannot be located, use BEAM FINDER switch). Position this display to the bottom of the graticule area with the right vertical unit position control.

14. Press the ALT or CHOP button of the VERTICAL MODE switch. A dual-trace display of the signal from the left vertical and right vertical plug-ins should be presented on the CRT. (For more information on choice of dual-trace mode, see Dual-Trace Displays in this section.)

15. If necessary, adjust the time-base triggering controls for a stable display.

16. Adjust the time-base position control so the display begins at the left graticule line. Set the time-base sweep rate for the desired horizontal display.

Dual-Sweep Display

The following procedure will provide a dual-sweep display of a single-trace vertical unit against two time-base units.

1. Install a 7A-series amplifier unit in the LEFT VERT compartment.

2. Press the LEFT button of the VERTICAL MODE switch.

3. Install 7B-series time-base units in both the A HORIZ and B HORIZ compartments.

4. Press the A button of the HORIZONTAL MODE switch.

5. Press the VERT MODE buttons of the A TRIGGER SOURCE and B TRIGGER SOURCE switches.

6. Set the POWER switch to ON. Allow several minutes warmup.

7. Connect the signal to the input connector of the vertical unit.

Operating Instructions—7904 Operators

8. Set the vertical unit for AC input coupling and calibrated deflection factors.

9. Set both time-base units for auto mode, internal triggering at a sweep rate of one millisecond/division.

10. Advance the A INTENSITY control until a display is visible (if display is not visible with A INTENSITY at midrange, press BEAM FINDER switch and adjust vertical deflection factor until display is reduced in size vertically; then center compressed display with vertical position control; release BEAM FINDER). Set the FOCUS control for a well-defined display.

11. Set the vertical unit for a display about four divisions in amplitude and move the display to the top of the graticule area with the vertical position control.

12. If necessary, set the A time-base unit for stable triggering.

13. Set the A time-base sweep rate for the desired display.

14. Press the B button of the HORIZONTAL MODE switch.

15. Advance the B INTENSITY control until a display is visible (if display is not visible with B INTENSITY at midrange, press BEAM FINDER switch and adjust the vertical deflection factor until display is reduced in size vertically; then center compressed display with vertical position control; release BEAM FINDER).

16. If necessary, set the B time-base unit for stable triggering.

17. Set the B time-base unit sweep rate for the desired display.

18. Press the ALT or CHOP button of the HORIZONTAL MODE switch (see Dual-Sweep Displays in this section for further information on selecting sweep mode).

19. Adjust the VERT TRACE SEPARATION (B) control to position the trace produced by the B time-base unit with respect to the trace produced by the A time-base unit.

Dual Trace—Dual Sweep Display

The following procedure will provide a dual-trace, dual-sweep display of two single-trace vertical units against two time-base units (four traces displayed on CRT).

1. Install 7A-series amplifier units in both vertical compartments.

2. Press the LEFT button of the VERTICAL MODE switch.

3. Install 7B-series time-base units in both horizontal compartments.

4. Press the B button of the HORIZONTAL MODE switch.

5. Press the VERT MODE buttons of the A TRIGGER SOURCE and B TRIGGER SOURCE switches.

6. Set the POWER switch to ON. Allow several minutes warmup.

7. Connect the signals to the input connectors of the vertical units.

8. Set the vertical units for AC input coupling and calibrated deflection factors.

9. Set both time-base units for auto mode, internal triggering at a sweep rate of one millisecond/division.

10. Advance the B INTENSITY control until a display is visible (if display is not visible with B INTENSITY at midrange, press BEAM FINDER switch and adjust the left vertical unit deflection factor until display is reduced in size vertically; then center compressed display with left vertical position control; release BEAM FINDER). Set the FOCUS control for a well-defined display.

11. Set the left vertical unit deflection factor for a display which is about two divisions in amplitude and position the display to the top of the graticule area.

12. If necessary, adjust the B time-base unit triggering controls for a stable display.

13. Position the start of the trace to the left graticule line with the B time-base unit position control. Set the B time-base unit sweep rate for the desired display.

14. Press the RIGHT button of the VERTICAL MODE switch and the A button of the HORIZONTAL MODE switch.

15. Advance the A INTENSITY control until a display is visible (if display is not visible with A INTENSITY at midrange, press BEAM FINDER switch and adjust the right vertical unit deflection factor until display is reduced in size vertically; then center compressed display with right vertical unit position control; release BEAM FINDER).

16. Set the right vertical unit deflection factor for a display about two divisions in amplitude and position the display just below the center horizontal line of the graticule.

17. If necessary, adjust the A time-base unit triggering controls for a stable display.

18. Position the start of the trace to the left graticule line with the A time-base unit position control. Set the A time-base sweep rate for the desired display.

19. Press the ALT or CHOP button of the HORIZONTAL MODE switch.

20. If necessary, adjust the VERT TRACE SEPARATION (B) control to separate the two traces.

21. Press the CHOP button of the VERTICAL MODE switch.

22. Adjust the vertical position controls and the VERT TRACE SEPARATION (B) control as necessary to obtain the desired display.

Independent-Pairs Display

The following procedure will provide a dual-trace, dual-sweep display where the left vertical unit is displayed

only at the sweep rate of the B time-base unit and the right vertical unit is displayed only at the sweep rate of the A time-base unit.

1. Follow steps 1 through 19 of the previous procedure for Dual-Trace/Dual-Sweep displays.

2. Press the ALT button of the VERTICAL MODE switch.

3. If necessary, adjust the position controls of the vertical units to separate the two traces. The vertical deflection produced by the unit in the LEFT VERT compartment is displayed at the sweep rate of the time-base in the B HORIZ compartment, and the vertical deflection produced by the unit in the RIGHT VERT compartment is displayed at the sweep rate of the time-base in the A HORIZ compartment.

Delayed Sweep—Single Trace Display

The following procedure will provide a delayed-sweep display of a single-trace vertical unit.

1. Follow the complete procedure given under Single-Trace Displays.

2. Be sure the time-base unit installed in the A HORIZ (DELAYING TIME BASE) compartment is a delaying time-base unit.

3. Install a 7B-series time-base unit in the B HORIZ compartment.

4. Follow the procedure given in the instruction manual for the delaying sweep time-base unit to obtain a delayed-sweep display.

5. Press the B button of the HORIZONTAL MODE switch and advance the B INTENSITY control until a display is visible. Only the delayed sweep is shown on this display.

6. Press the ALT or CHOP button of the HORIZONTAL MODE switch.

7. If necessary, adjust the VERT TRACE SEPARATION (B) control to separate the two traces. This display provides a simultaneous presentation of the delaying (A HORIZ) time-base unit and the delayed (B HORIZ) time-base unit.

Delayed Sweep—Dual Trace

The following procedure will provide a delayed-sweep display of two single-trace vertical units (four traces displayed on screen).

1. Follow the complete procedure given under Dual-Trace Displays.
2. Be sure the time-base unit installed in the A HORIZ (DELAYING TIME BASE) compartment is a delaying time-base unit.
3. Install a 7B-series time-base unit in the B HORIZ compartment.
4. Follow the procedure given in the instruction manual for the delaying sweep time-base unit to obtain a delayed-sweep display.
5. Press the B button of the HORIZONTAL MODE switch and advance the B INTENSITY control until a display is visible. Only the delayed sweep display of both vertical traces is shown on this display.
6. Press the ALT or CHOP button of the HORIZONTAL MODE switch.
7. Adjust the vertical position controls and the VERT TRACE SEPARATION (B) control as necessary to obtain the desired display.

NOTE

When operated in the delayed-sweep mode, there is no special display relationship between the vertical and horizontal plug-ins as for independent-pairs operation, regardless of the vertical mode selected.

X-Y Display

The following procedure will provide an X-Y display (one signal versus another rather than against time).

NOTE

Some 7B-series time-base units have provisions for amplifier operation in the X-Y mode; see X-Y Operation in this section for details of operation in this manner.

1. Install 7A-series amplifier units in both the LEFT VERT and the A HORIZ compartments.

2. Press the LEFT button of the VERTICAL MODE switch and the A button of the HORIZONTAL MODE switch.

3. Set the POWER switch to ON. Allow several minutes warmup.

4. Connect the X-signal to the amplifier unit in the A HORIZ compartment.

5. Connect the Y-signal to the amplifier unit in the LEFT VERT compartment.

6. Set both amplifier units for AC input coupling and calibrated deflection factors.

7. Advance the A INTENSITY control until a display is visible (if display is not visible, press BEAM FINDER switch and adjust the deflection factors of both amplifier units until display is reduced in size both vertically and horizontally; then center compressed display with the position controls; release BEAM FINDER).

8. Set the deflection factor of both amplifier units for the desired display and center the display with the position controls. The amplifier unit in the A HORIZ compartment controls the horizontal deflection, and the unit in the LEFT VERT compartment controls the vertical deflection.

GENERAL OPERATING INFORMATION

Intensity Controls

General. The 7904 has three separate intensity controls. The A INTENSITY control determines the brightness of the display produced by the plug-in unit in the A HORIZ compartment. Likewise, the B INTENSITY control determines the brightness of the display produced by the plug-in unit in the B HORIZ compartment. The READOUT intensity control determines the brightness of only the readout portion of the CRT display.

CRT Phosphor Protection. To protect the CRT phosphor, this instrument contains protection circuitry which limits the display intensity by limiting the CRT beam current to a safe level. If the intensity control(s) is advanced to a point where the CRT beam current exceeds a potentially damaging level for more than about ten milli-

seconds, the circuit action automatically limits the beam current to a safe level. This circuit action also de-focuses the trace to indicate that the setting of the intensity control(s) should be reduced. The CRT beam current is limited to an even lower level when operating in an X-Y mode, or if either one of the time-base units is set to a slow sweep rate (even if the time-base unit with slow sweep rate is not selected for display by the HORIZONTAL MODE switch). This reduces the danger of damaging the CRT phosphor with a stationary or slowly moving spot. Since beam-current limiting does not take effect until after about ten milliseconds, the full display-intensity capability of the 7904 is available for most single-shot and photography uses.

Light Filters. Light filters reduce the observed light output from the CRT. When the highest intensity display is desired, remove the filters and use only the clear faceplate protector (permanently installed behind bezel). Apparent trace intensity can also be improved in such cases by reducing the ambient light or using a viewing hood.

Display Focus

This instrument contains an automatic-focusing circuit which maintains optimum focus after correct setting of the FOCUS control is established. This eliminates the need to re-adjust the FOCUS control for various intensity settings within the range of the CRT phosphor-protection circuitry (see CRT Phosphor Protection). Set the FOCUS control for best definition of a low-intensity display.

Astigmatism Adjustment

If a well-defined display cannot be obtained with the FOCUS control, adjust the ASTIG adjustment as follows:

NOTE

To check for proper setting of the ASTIG adjustment, slowly turn the FOCUS control through the optimum setting. If the ASTIG adjustment is correctly set, the vertical and horizontal portions of the display will come into sharpest focus at the same position of the FOCUS control. This setting of the ASTIG adjustment should be correct for any display.

1. Connect the CAL VOLTS connector to the input of the vertical unit with a BNC-to-BNC jumper lead.

2. Set the CALIBRATOR switch to 4 V and the RATE switch to 1 kHz. Adjust the vertical deflection factor to produce a two- or three-division display.

3. Set the time-base unit for a sweep rate of 0.2 millisecond/division.

4. Set the A INTENSITY control so the display is at normal intensity (about midrange).

5. Turn the FOCUS control fully counterclockwise and set the ASTIG adjustment to midrange.

6. Adjust the FOCUS control so the top and bottom of the displayed square wave are as thin as possible, but not elongated.

7. Set the ASTIG adjustment so the top and bottom of the displayed square wave are as thin as possible.

8. Repeat parts 6 and 7 for the best overall focus.

Trace Alignment Adjustment

If a free-running trace is not parallel with the horizontal graticule lines, set the TRACE ROTATION adjustment as follows: Position the trace to the center horizontal line and adjust the TRACE ROTATION adjustment so the trace is parallel with the horizontal graticule lines.

Graticule

The graticule of the 7904 is internally marked on the faceplate of the CRT to provide accurate, no-parallax measurements. The graticule is divided into eight vertical and ten horizontal divisions. In addition, each major division is divided into five minor divisions at the center vertical and horizontal lines. The vertical gain and horizontal timing of the plug-ins are calibrated to the graticule so accurate measurements can be made from the CRT. The illumination of the graticule lines can be varied with the GRAT ILLUM control.

Fig. 2-4 shows the graticule of the 7904 and defines the various measurement lines. The terminology defined here will be used in all discussions involving graticule measurements. Notice the 0%, 10, 90, and 100 markings on the left side of the graticule. These markings are provided to facilitate risetime measurements.

Light Filter

The tinted filter provided with the 7904 minimizes light reflections from the face of the CRT to improve contrast when viewing the display under high ambient light conditions. This filter should be removed for waveform photographs or when viewing high writing rate displays. To remove the filter, pull outward on the bottom of the plastic CRT mask and remove it from the CRT. Remove the tinted

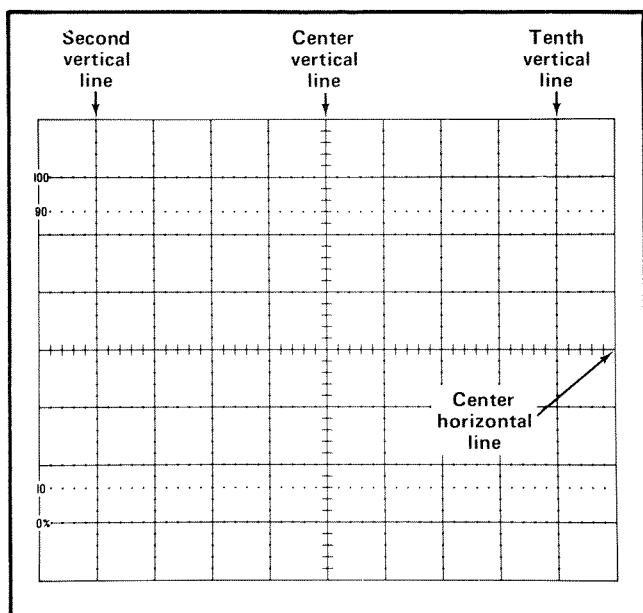

Fig. 2-4. Definition of measurement lines on 7904 graticule.

2. While the display is compressed, increase the vertical and horizontal deflection factors until the vertical deflection is reduced to about two divisions and the horizontal deflection is reduced to about four divisions (the horizontal deflection needs to be reduced only when in the X-Y mode of operation).

3. Adjust the vertical and horizontal position controls to center the display about the vertical and horizontal center lines of the graticule.

4. Release the BEAM FINDER switch; the display should remain within the viewing area.

Control Illumination

The CONTROL ILLUM switch determines the illumination level of the pushbutton switches on the 7904 and the associated plug-in units. This switch controls the illumination of only the pushbutton switches on the plug-in units, and does not affect the intensity of lights which are used as function indicators (for example, it does not affect the illumination of the ready light on a time-base unit which has the single-sweep feature). In the OFF position, all pushbutton lights on the 7904 and the associated plug-ins are off. The A and B INTENSITY lights remain on at low intensity to provide a power-on indication. In the LOW position, the selected buttons are illuminated at low intensity. This is the recommended position for the CONTROL ILLUM switch, since it provides an adequate indication of switch position and also results in longest bulb life. The HIGH position provides maximum intensity for the pushbuttons and can be used so the selected switch is obvious even under high ambient light conditions.

NOTE

If the Readout System is not installed in this instrument (Option 1), disregard the following information. Also, the READOUT control has no effect upon instrument operation in this case.

Readout

The Readout System of the 7904 allows alpha-numeric display of information on the CRT along with the analog waveform displays. The information displayed by the Readout System is obtained from the plug-in units which are installed in the plug-in compartments. The characters of the readout display are written by the CRT beam on a time-shared basis with the signal waveforms.

The Readout Mode switch, located behind the right side panel (see Fig. 2-5), determines the operating mode of the Readout System. When this switch is in the Free Run—

filter (leave the metal light shield in place) and snap the plastic CRT mask back into place. A clear plastic faceplate protector is mounted between the CRT faceplate and the bezel. This faceplate protector should be left in place at all times to protect the CRT faceplate from scratches.

An optional mesh filter is available for use with the 7904 (included with Option 3). This filter provides shielding against radiated EMI (electro-magnetic interference) from the face of the CRT. It also serves as a light filter to make the trace more visible under high ambient light conditions. The mesh filter fits in place of the plastic CRT mask and the tinted filter. The filter can be ordered by Tektronix Part No. 378-0603-00.

Beam Finder

The BEAM FINDER switch provides a means of locating a display which overscans the viewing area either vertically or horizontally. When the BEAM FINDER switch is pressed, the display is compressed within the graticule area. This switch can also be pulled outward to lock it in the beam-finder position. The latter feature is convenient when attempting to locate traces from more than one of the plug-in units in the 7904. Press the BEAM FINDER switch in to release it from the locked position. To locate and reposition an overscanned display, use the following procedure:

1. Press the BEAM FINDER switch in (or if desired, pull it outward to the lock position).

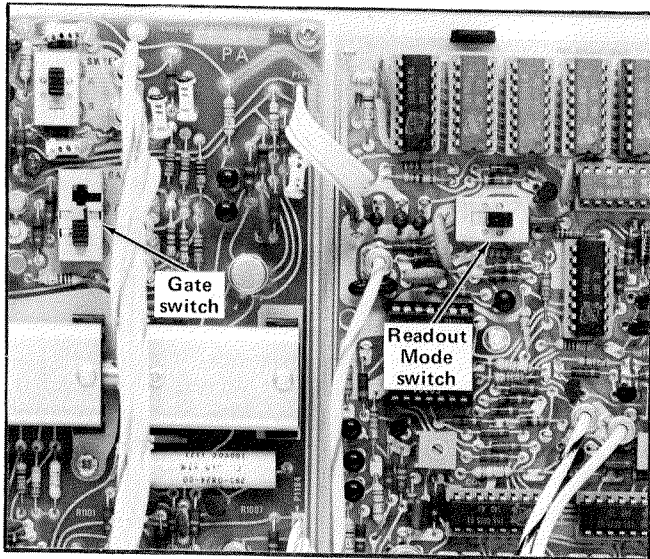

Fig. 2-5. Location of Readout Mode and Gate switches (behind right side panel).

Remote position, the Readout System operates in a free-running mode to randomly interrupt the waveform display to display characters. However, the waveform display is interrupted for only about 20 microseconds for each character that is displayed. The Readout System can also be remotely switched to the single-shot mode when in this position (see Remote Readout for further information). In the Gate Trig'd position, the Readout System is locked out so no characters are displayed during the sweep. At the end of the sweep, the Readout System is triggered and a complete frame of all applicable readout words is displayed. This mode of operation can be used when the trace interruptions necessary to display characters would not otherwise allow a satisfactory waveform display to be obtained. The trigger for the Readout System in the Gate Trig'd position is produced from the sweep gate selected by the Gate switch (located on the Output Signals and Calibrator board; see Fig. 2-5) and is the same as the gate signal connected to the front-panel +GATE connector (time-base unit must be installed in selected horizontal compartment).

The readout information from each plug-in channel is called a word. Up to eight words of readout information can be displayed on the 7904 CRT (two channels from each of the four plug-in compartments). The location at which each readout word is presented is fixed and is directly related to the plug-in unit and channel from which it originated. Fig. 2-6 shows the area of the graticule where the readout from each plug-in unit and channel is displayed. Notice that the readout from channel 1 of each plug-in unit is displayed within the top division of the graticule, and the readout from channel 2 is displayed directly below within the bottom division of the graticule. Only the readout from plug-ins and/or channels which are selected for display by the VERTICAL MODE or HORIZONTAL MODE switches,

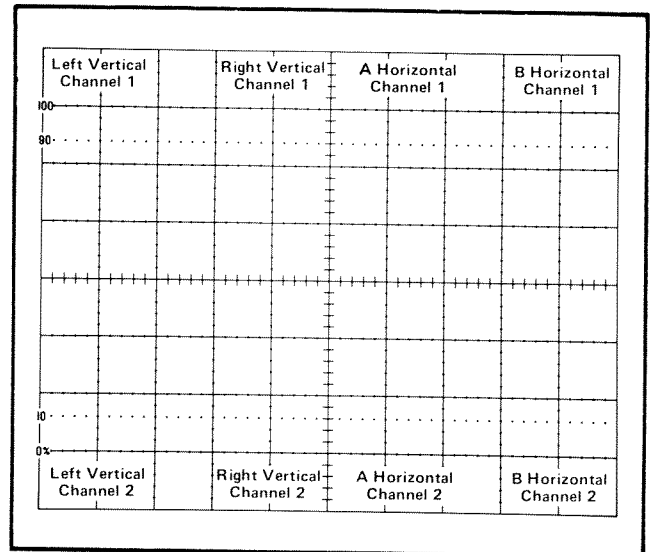

Fig. 2-6. Location of readout on the CRT identifying the originating plug-in and channel.

or by the mode switches of dual-channel plug-ins, appear in the readout display (some special purpose plug-in units may over-ride the mode switches to display readout even though the compartment is not selected for waveform display).

An "identify" feature is provided by the Readout System to link the readout word with the originating plug-in unit and channel (amplifier units only). When the "Identify" button of an amplifier unit is pressed, the word IDENTIFY appears in the readout location allocated to that plug-in and channel. Other readout words in the display remain unchanged. When the "Identify" button is released, the readout display from this plug-in channel is again displayed. Circuitry may also be provided in the amplifier unit which produces a noticeable change in the analog waveform display to also identify the associated trace when the "Identify" button is pressed; see the plug-in instruction manuals for details.

The READOUT control determines the intensity of only the readout portion of the display independent of the other traces. The Readout System is inoperative in the fully counterclockwise OFF position. This may be desirable when the top and bottom divisions of the graticule are to be used for waveform display.

Remote Readout

The operating mode of the Readout System can be remotely controlled through the rear-panel Remote control connector J90. Grounding Pin E inhibits (locks out) the Readout System; grounding Pin F triggers one complete frame of applicable readout words (single-shot). This mode of operation can be used to display the readout inde-

Operating Instructions—7904 Operators

pendent of the waveforms, such as for display photography. Requirements for remote readout operation are:

REMOTE READOUT LOCKOUT

Pin of J90	E
Signal Required	Closure to ground (within 0.1 volt) from a positive level locks out Readout System
Maximum current required	Two milliamperes
Maximum open circuit voltage	+2 volts
Maximum safe input voltage	+5 volts, -1 volt (DC + peak AC)

REMOTE SINGLE-SHOT READOUT

Pin of J90	F
Signal required	Closure to ground (within 0.4 volt) from a positive level with pin E grounded allows Readout System to display one complete frame. Rate of change must be at least 0.1 volt/microsecond.
Maximum current required	Three milliamperes
Maximum open circuit voltage	+10 volts
Maximum safe input voltage	+10 volts, -5 volts (DC + peak AC)

Display Photography

A permanent record of the CRT display can be obtained with an oscilloscope camera system. The instruction manuals for the Tektronix Oscilloscope Cameras include complete instructions for obtaining waveform photographs. The following specific information applies to the 7904.

The CRT bezel of the 7904 provides integral mounting for a Tektronix Oscilloscope Camera. The three pins located on the left side of the CRT bezel connect power to compatible camera systems. Control signals are also received from Tektronix automatic cameras to allow camera-controlled single-shot photography (see camera manual for further information).

If the readout portion of the display is to be included on waveform photographs, the following suggestions will aid in obtaining good photographs.

1. Focus the oscilloscope display and the camera on the center of the CRT display. The auto-focus feature in this instrument will maintain the traces at optimum focus.

2. Set the READOUT intensity control for a minimum setting that allows the characters to be written. This normally occurs at a slightly lower intensity level than is necessary for complete writing of the waveform display. Some experimentation may be necessary to establish the correct level. Too high a setting of the READOUT intensity control will result in a broad, poorly defined photograph of the readout display.

3. If single-shot photography is used, set the Readout Mode switch to the Gate Trig'd position (see Readout for complete operating information). Then, the readout is displayed in a single-shot manner after the trace is complete (be sure the camera shutter remains open at least 0.5 second after the sweep is completed to photograph the entire readout). Also, set the GRAT ILLUM control counterclockwise while the trace is being photographed. Then, the graticule can be photographed later to produce a double-exposure picture showing complete information.

Vertical and Horizontal Mode Switch Logic

There are 20 possible combinations of VERTICAL MODE and HORIZONTAL MODE switch settings. The total possible number of display combinations is further multiplied by the variety of plug-in units available for use with this instrument (such as voltage amplifiers, current amplifiers, sampling units, etc.), the interchangeability of plug-ins (i.e., an amplifier or time-base unit can be installed in either of the vertical or horizontal compartments), or by the capabilities of the plug-in units which are used in this instrument (e.g., a dual-trace vertical unit can be used in either of the two single-channel modes, in either dual-trace mode, or added algebraically; a delaying time base may be used either for a normal sweep or for delayed sweep). Therefore, it is difficult to list all of the display combinations which can occur using the 7904 and the plug-in units which are available, since the display combinations possible are dictated by the specific combination of plug-in units used. Table 2-1 lists the combination of VERTICAL MODE and HORIZONTAL MODE switch positions available and the type of display provided with each combination. For further information on operation in each position of the VERTICAL MODE and HORIZONTAL MODE switch positions, see the following sections on Vertical Mode and Horizontal Mode.

TABLE 2-1
Display Combinations¹

VERTICAL MODE Switch Position	HORIZONTAL MODE Switch Position	Comments
LEFT	A	One trace. Vertical deflection from single unit; horizontal deflection from single unit.
	B	One trace. Vertical deflection from single unit; horizontal deflection from single unit.
	ALT	Two traces. Vertical deflection from single unit; horizontal deflection from both units.
	CHOP	Two traces. Vertical deflection from single unit; horizontal deflection from both units.
ALT	A	Two traces. Vertical deflection from both units; horizontal deflection from single unit.
	B	Two traces. Vertical deflection from both units; horizontal deflection from single unit.
	ALT	Two traces. Vertical deflection from both units; horizontal deflection from both units. Provides independent-pairs operation between the LEFT VERT and B HORIZ plug-ins and the RIGHT VERT and A HORIZ plug-ins (except for delayed-sweep operation).
	CHOP	Two traces. Vertical deflection from both units; horizontal deflection from both units. Provides independent-pairs operation between the LEFT VERT and B HORIZ plug-ins and the RIGHT VERT and A HORIZ plug-ins (except for delayed-sweep operation).
ADD	A	One trace. Vertical deflection is algebraic summation of both units; horizontal deflection from single unit.
	B	One trace. Vertical deflection is algebraic summation of both units; horizontal deflection from single unit.
	ALT	Two traces. Vertical deflection is algebraic summation of both units; horizontal deflection from both units.
	CHOP	Two traces. Vertical deflection is algebraic summation of both units; horizontal deflection from both units.
CHOP	A	Two traces. Vertical deflection from both units; horizontal deflection from single unit.
	B	Two traces. Vertical deflection from both units; horizontal deflection from single unit.
	ALT	Four traces. Vertical deflection from both units; horizontal deflection from both units.
	CHOP	Four traces. Vertical deflection from both units; horizontal deflection from both units.
RIGHT	A	One trace. Vertical deflection from single unit; horizontal deflection from single unit.
	B	One trace. Vertical deflection from single unit; horizontal deflection from single unit.
	ALT	Two traces. Vertical deflection from single unit; horizontal deflection from both units.
	CHOP	Two traces. Vertical deflection from single unit; horizontal deflection from both units.

¹ Combinations given for single-channel vertical and horizontal units only.

Vertical Mode

Left and Right Mode. When the LEFT or RIGHT button of the VERTICAL MODE switch is pressed, only the signal from the plug-in unit in the selected compartment is displayed.

Alternate Mode. The ALT position of the VERTICAL MODE switch produces a display which alternates between the plug-in units in the LEFT VERT and RIGHT VERT compartments with each sweep of the CRT. Although the ALT mode can be used at all sweep rates, the CHOP mode provides a more satisfactory display at sweep rates below about 20 milliseconds/division. At these slower sweep rates, alternate-mode switching becomes visually perceptible.

The A and B TRIGGER SOURCE switches allow selection of the triggering for an alternate display. When these switches are set to the VERT MODE positions, each sweep is triggered by the signal being displayed on the CRT. This provides a stable display of two unrelated signals, but does not indicate the time relationship between the signals. In either the LEFT VERT or the RIGHT VERT positions, the two signals are displayed showing true time relationship. However, if the signals are not time-related, the display from the plug-in which is not providing a trigger signal will be unstable on the CRT.

When the ALT vertical mode is selected and either the ALT or CHOP buttons of the HORIZONTAL MODE switch are pressed, the instrument operates in the independent-pairs mode. Under this condition, the left vertical unit is always displayed at the sweep rate of the time-base unit in the B HORIZ compartment and the right vertical unit is displayed at the sweep rate of the time-base unit in the A HORIZ compartment (non-delayed sweep only). This results in two displays that have completely independent vertical deflection and sweep rate. This display is equivalent to the display obtainable with a dual-beam oscilloscope for most repetitive display combinations. See Horizontal Mode for information on selection of either ALT or CHOP horizontal mode. See Trigger Source for information on obtaining correct trigger operation. If delayed-sweep operation is used under this condition, a different sequence of display occurs. First, the left vertical unit is displayed at the sweep rate of the time-base unit in the A HORIZ compartment (delaying sweep) and then at the sweep rate of the time-base unit in the B HORIZ compartment (delayed sweep). The vertical display then shifts to the right vertical unit and it is displayed consecutively at the delaying and delayed sweep rate.

Chopped Mode. The CHOP position of the VERTICAL MODE switch produces a display which is electronically switched between channels at a one-megahertz rate. In general, the CHOP mode provides the best display at sweep

Operating Instructions—7904 Operators

rates slower than about 20 milliseconds/division or whenever dual-trace, single-shot phenomena are to be displayed. At faster sweep rates, the chopped switching becomes apparent and may interfere with the display.

Correct internal triggering for the CHOP mode can be obtained in any of the three positions of the trigger source switches. When the A or B TRIGGER SOURCE switches are set to VERT MODE or LEFT VERT, the internal trigger signal is obtained from the left vertical plug-in unit. Use of the RIGHT VERT trigger source position triggers the time-base units on the internal trigger signal from the right vertical unit. This allows two time-related signals to be displayed showing true time relationship. However, if the signals are not time-related, the display from the channel which is not providing the trigger signal will appear unstable. The CHOP mode can be used to compare two single-shot, transient, or random signals which occur within the time interval determined by the time-base unit (ten times selected sweep rate). To provide correct triggering, the display which provides the trigger signal must precede the second display in time. Since the signals show true time relationship, time-difference measurements can be made from the display.

Algebraic Addition. The ADD position of the VERTICAL MODE switch can be used to display the sum or difference of two signals, for common-mode rejection to remove an undesired signal, or for DC offset (applying a DC voltage to one channel to offset the DC component of a signal on the other channel). The common-mode rejection ratio between the vertical plug-in compartments of the 7904 is at least 5:1 at 500 megahertz. The rejection ratio increases to 100:1 at 100 megahertz.

The overall deflection on the CRT in the ADD mode is the resultant of the algebraic addition of the signals from the two vertical plug-in units. It is difficult to determine the voltage amplitude of the resultant display unless the amplitude of the signal applied to one of the plug-ins is known. This is particularly true when the vertical units are set to different deflection factors, since it is not obvious which portion of the display is a result of the signal applied to either plug-in unit. Also, the polarity and repetition rate of the applied signals enters into the calculation.

The following general precautions should be observed to provide the best display when using the ADD mode:

1. Do not exceed the input voltage rating of the plug-in units.
2. Do not apply large signals to the plug-in inputs. A good rule to follow is not to apply a signal which exceeds

an equivalent of about eight times the vertical deflection factors. For example, with a vertical deflection factor of 0.5 volt/division, the voltage applied to that plug-in should not exceed four volts. Larger voltages may result in a distorted display.

3. To ensure the greatest dynamic range in the ADD mode, set the position controls of the plug-in units to a setting which would result in a mid-screen display if viewed in the LEFT or RIGHT positions of the VERTICAL MODE switch.

4. For similar response from each channel, set the plug-in units for the same input coupling.

Horizontal Mode

A and B. When either the A or B button of the HORIZONTAL MODE switch is pressed, the display is presented at the sweep rate of only the selected time-base unit. Set the applicable intensity control and trigger source switch for the desired display.

Alternate Mode. The ALT position of the HORIZONTAL MODE switch produces a display which alternates between time-base units after each sweep on the CRT. Although the ALT horizontal mode can be used at all sweep rates, the CHOP horizontal mode provides a more satisfactory display at sweep rates below about 20 milliseconds/division. At slower sweep rates, the switching between the alternate-mode traces becomes apparent and may interfere with correct analysis of the display.

NOTE

This instrument will not operate in the ALT position of the HORIZONTAL MODE switch if either horizontal plug-in compartment is left vacant.

The A and B INTENSITY controls allow individual adjustment of the traces produced by the time-base units in the A HORIZ and B HORIZ compartments. Correct triggering of both time-base units is essential to obtaining the correct display in the ALT horizontal mode. If either of the time-base units does not receive a correct trigger, and therefore does not produce a sweep, the other unit cannot produce a sweep either. This means that one time-base unit cannot begin its sweep until the previous unit has completed its entire display. This can be avoided if the time-base units are set for auto-mode triggering (sweep free runs if not correctly triggered). The A and B TRIGGER SOURCE switches allow individual selection of the trigger source for the A HORIZ and B HORIZ time-base units. See the information on Trigger Source for complete operation

of the A and B TRIGGER SOURCE switches. Also, see Vertical Trace Separation for information on positioning the B HORIZ display when in the ALT dual-sweep mode.

Chopped Mode. When the CHOP button of the HORIZONTAL MODE switch is pressed, the display is electronically switched between the two time-base units at a 200-kilohertz rate. In general, the CHOP horizontal mode provides the best display when either of the time-base units is set to a sweep rate slower than about 20 milliseconds/division. It also provides the best display when the two time-base units are set to widely varying sweep rates. In the CHOP horizontal mode, equal time segments are displayed from each of the time-base units. This provides a display which does not change greatly in intensity as the sweep rate of one of the time-base units is reduced (in contrast to ALT horizontal mode operation, where the slowest trace tends to be the brightest).

The A and B INTENSITY controls allow individual adjustment of the intensity of the traces produced by the time-base units in the A HORIZ and B HORIZ compartments respectively. Triggering is not as critical in the CHOP horizontal mode as in ALT, since only the trace from the un-triggered time-base unit is missing from the display if one of the units is not triggered properly. The other trace will be presented in the normal manner. The A and B TRIGGER SOURCE switches allow individual selection of the trigger source for the A HORIZ and B HORIZ time-base units. See the information on Trigger Source. Also, see Vertical Trace Separation for information on positioning the trace produced by the B HORIZ unit in relation to the trace from the A HORIZ unit.

Vertical Trace Separation

The VERT TRACE SEPARATION (B) control allows the trace produced by the B HORIZ plug-in to be positioned about four divisions above or below the trace produced by the plug-in unit in the A HORIZ compartment when one of the dual-sweep horizontal modes is selected. This control effectively operates as a vertical position control for all dual-sweep modes except independent-pairs operation. Then, the vertical position of the B HORIZ trace is determined by the plug-in unit in the LEFT VERT compartment only.

To use the VERT TRACE SEPARATION (B) control, first establish the desired portion of the trace produced by the unit in the A HORIZ compartment. Then adjust the VERT TRACE SEPARATION (B) control to move the trace produced by the unit in the B HORIZ compartment away from the A HORIZ display. If both of the waveforms are larger than four divisions in amplitude, the displays can only be positioned so they do not directly overlap, since each waveform cannot be positioned to a unique area of the CRT.

Trigger Source

The A and B TRIGGER SOURCE switches allow selection of the internal trigger signals for the A HORIZ and B HORIZ time-base units respectively. For most applications, these switches can be set to the VERT MODE positions. This position is the most convenient, since the internal trigger signal is automatically switched as the VERTICAL MODE switch is changed. Table 2-2 shows the internal trigger source selected in the VERT MODE position of both trigger source switches for each position of the VERTICAL MODE switch.

TABLE 2-2
VERT MODE
Trigger Source

VERTICAL MODE Switch Position	Trigger Source for A and B HORIZ units
LEFT	LEFT VERT unit only
ALT	Determined by HORIZONTAL MODE Switch (see Table 2-3)
ADD	Algebraic sum of signals from LEFT and RIGHT VERT units
CHOP	LEFT VERT unit only
RIGHT	RIGHT VERT unit only

The internal trigger signal obtained in the ADD position of the VERTICAL MODE switch is a composite of the signals from the left and right vertical plug-in units. In the ALT position of the VERTICAL MODE switch, the internal trigger source is pre-selected by the HORIZONTAL MODE switch. This automatically selects the proper trigger source for the A and B time-base units for independent-pairs operation (ALT vertical mode with ALT or CHOP horizontal mode unless time-base units are set for delayed-sweep operation; see Independent-Pairs Operation). For the A or B positions of the HORIZONTAL MODE switch, the internal trigger signal is automatically switched as the display is electronically switched between the LEFT VERT and RIGHT VERT plug-ins. Table 2-3 shows the trigger source selected in the ALT vertical mode for the A HORIZ and B HORIZ time-base units for each position of the HORIZONTAL MODE switch. Therefore, the VERT MODE positions ensure that the time-base units receive a trigger signal regardless of the mode switch settings without the need to change the trigger source selection.

The pushbuttons of the A and B TRIGGER SOURCE switches are illuminated (CONTROL ILLUM switch set to LOW or HIGH) to indicate the selected position (VERT MODE) and the actual internal trigger source obtained as a result of the VERTICAL and HORIZONTAL MODE switch

Operating Instructions—7904 Operators

settings and operating mode of the time-base units (LEFT VERT and/or RIGHT VERT).

TABLE 2-3
A and B VERT MODE Trigger Source for ALT Vertical Mode

HORIZONTAL MODE Switch Position	Trigger Source	
	A	B
A	Alternates between vertical units (follows display).	
ALT	² RIGHT VERT unit	² LEFT VERT unit
CHOP	² RIGHT VERT unit	² LEFT VERT unit
B	Alternates between vertical units (follows display).	

² Alternates between vertical units when time-base units are set for delayed-sweep operation.

If correct triggering for the desired display is not obtained in the VERT MODE position, the trigger source for either the A HORIZ or B HORIZ time-base unit can be changed to obtain the trigger signal from either the LEFT VERT or RIGHT VERT plug-in. The internal trigger signal is obtained from the selected vertical compartment, whether the plug-in in that compartment is selected for display on the CRT or not. If the internal trigger signal is obtained from one of the vertical units, but the other vertical unit is selected for display, the internal trigger signal must be time-related to the displayed signal in order to obtain a triggered (stable) display.

X-Y Operation

In some applications, it is desirable to display one signal versus another (X-Y) rather than against time (internal sweep). The flexibility of the plug-in units available for use with the 7904 provides a means for applying an external signal to the horizontal deflection system for this type of display. Some of the 7B-series time-base units can be operated as amplifiers in addition to their normal use as time-base generators. This feature allows an external signal to provide the horizontal deflection on the CRT. For most of the time-base units with the amplifier function, the X (horizontal) signal can be connected either to an external input connector on the time-base unit or it can be routed to the time-base through the internal triggering system (see time-base instruction manual for details). If the latter method is used, the A and B TRIGGER SOURCE switches must be set so that the X (horizontal) signal is obtained from one of the vertical units and the Y (vertical) signal is obtained from the other vertical unit. The advantages of

using the internal trigger system to provide the X signal are that the attenuator switch of the amplifier unit providing the horizontal signal determines the horizontal deflection factor to allow full-range operation, and the plug-in units do not have to be moved between compartments when X-Y operation is desired.

Another method of obtaining an X-Y display is to install an amplifier plug-in unit in one of the horizontal plug-in compartments (check amplifier unit gain as given in the plug-in instruction manual to obtain calibrated horizontal deflection factors). This method provides the best X-Y display, particularly if two identical amplifier units are used, since both the X and Y input systems will have the same delay time, gain characteristics, input coupling, etc. For further information on obtaining X-Y displays, see the plug-in unit manuals. Also, the reference books listed under Applications provide information on X-Y measurements and interpreting the resultant lissajous displays.

An optional X-Y delay compensation network is available for use with the 7904. This network provides close delay matching between the vertical and horizontal deflection systems up to one megahertz for use in X-Y applications which require precise phase measurement. The network can be added to the 7904 at any time. Order the X-Y Conversion kit from your local Tektronix Field Office or representative; installation instructions are included.

While the X-Y delay compensation network provides minimum phase shift between the X and Y portions of an X-Y display, it adds negative preshoot distortion and some corner rounding to fast step functions. An internal Delay Disable switch (see Fig. 2-7) is provided for both the A and

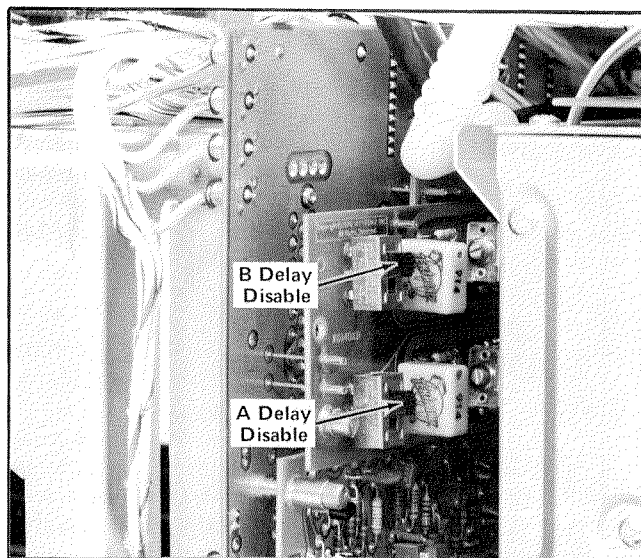

Fig. 2-7. Location of A and B Delay Disable switches (behind right side panel).

B delay compensation networks to allow selection of either minimum phase-shift characteristics or optimum step response. When the Delay Disable switch is set to In (up), minimum phase-shift operation is provided as controlled by the plug-in units in the associated horizontal compartment. When set to the Out (down) position, the X-Y delay compensation network for the applicable horizontal compartment is disabled; the horizontal signal is connected to the horizontal deflection system with minimum distortion.

Intensity Modulation

Intensity (Z-axis) modulation can be used to relate a third item of electrical phenomena to the vertical (Y-axis) and the horizontal (X-axis) coordinates without affecting the waveshape of the displayed signal. The Z-axis modulating signal applied to the CRT circuit changes the intensity of the displayed waveform to provide this type of display. "Gray scale" intensity modulation can be obtained by applying signals which do not completely blank the display. Large amplitude signals of the correct polarity will completely blank the display; the sharpest display is provided by signals with a fast rise and fall. The voltage amplitude required for visible trace modulation depends on the setting of the intensity controls.

Time markers applied to the Z-AXIS INPUT provide a direct time reference on the display. With uncalibrated horizontal sweep or X-Y mode operation, the time markers provide a means of reading time directly from the display. However, if the markers are not time-related to the displayed waveform, a single-sweep display should be used (for internal sweep only) to provide a stable display.

The Z-AXIS INPUT (on rear panel) permits intensity modulation of the CRT display through the intensity circuit. Negative-going signals increase the display intensity and positive-going signals decrease the display intensity. At DC and low frequencies, a two-volt peak-to-peak signal will completely blank the display even at maximum intensity levels. At higher frequencies, the signal characteristics necessary to obtain intensity modulation without distortion are determined by the intensity circuit pulse performance characteristics (see Section 1). The maximum input voltage should be limited to 15 volts (DC plus peak AC). When the Z-AXIS INPUT is not in use, replace the BNC cap.

Raster Display

A raster-type display can be used to effectively increase the apparent sweep length. For this type of display, the trace is deflected both vertically and horizontally by sawtooth signals. This is accomplished in the 7904 by installing a 7B-series time-base unit in one of the vertical plug-in compartments. Normally, the time-base unit in the vertical compartment should be set to a slower sweep rate

than the time-base unit in the horizontal compartment; the number of horizontal traces in the raster depends upon the ratio between the two sweep rates. Information can be displayed on the raster using several different methods. In the ADD position of the VERTICAL MODE switch, the signal from an amplifier unit can be algebraically added to the vertical deflection. With this method, the vertical signal amplitude on the CRT should not exceed the distance between the horizontal lines of the raster. Another method of displaying information on the raster is to use the Z-AXIS INPUT to provide intensity modulation for the display. This type of raster display could be used to provide a television-type display. Complete information on operation using the Z-axis feature is given under Intensity Modulation.

To provide a stable raster display, both time-base units must be correctly triggered. Internal triggering is not provided for the time-base units when they are in the vertical compartments; external triggering must be used. Also, blanking is not provided from the time-base units when they are installed in a vertical compartment. To blank out the retrace portion from the time-base unit in the vertical compartment, special connections must be made from this time-base unit to the blanking network of the 7904 (for further information, see the instruction manual for the applicable time-base unit).

Calibrator

General. The internal calibrator of the 7904 provides a convenient signal source for checking basic vertical gain and sweep timing. The calibrator output signal is also very useful for adjusting probe compensation as described in the probe instruction manual. In addition, the calibrator can be used as a convenient signal source for application to external equipment.

Voltage. The calibrator provides accurate output voltages at the CAL VOLTS connector from four millivolts to 40 volts in decade steps into high impedance loads. In addition, the positions from 4 mV to 4 V provide an output of two millivolts to 0.4 volt into 50 ohms (shown on front panel in brackets). The amplitude of the output voltage is selected by the CALIBRATOR switch. The output voltage is available at the front-panel CAL VOLTS connector.

Current. The current loop provides a 40-milliampere output current which can be used to check and calibrate current-measuring probe systems. The current output is selected by the CALIBRATOR switch when set to the 40 mA position. The current signal is obtained by clipping the probe around the current loop. The arrow above the current loop indicates conventional current flow; i.e., from plus to minus.

Repetition Rate. The calibrator circuit uses frequency-stable components to maintain accurate frequency and constant duty cycle. Thus, the calibrator can be used for checking the basic sweep timing of time-base units (one-kilohertz rate only). The RATE switch selects the repetition rate of the calibrator. Two positions of the RATE switch provide a square-wave output signal both at the CAL VOLTS connector and through the current loop. In the 1 kHz position, the repetition rate of the calibrator is one kilohertz. The B GATE $\div 2$ position of the RATE switch provides a variable calibrator repetition rate. In this position, the repetition rate of the calibrator output signal is one-half the repetition rate of the gate signal produced by the time-base unit in the B HORIZ compartment (length of B gate is about ten times the setting of the B sweep rate switch). This position of the RATE switch allows selection of the repetition rate of the calibrator output signal by changing the sweep rate of the time-base unit in the B HORIZ compartment. The calibrator circuit maintains a constant 50% duty cycle on the output waveform, regardless of the repetition rate (B time base free running).

In the DC position, positive DC voltage levels are available at the CAL VOLTS connector; the amplitude of the DC voltage is determined by the setting of the CALIBRATOR switch to one of the voltage ranges. When the CALIBRATOR switch is set to the 40 mA position, a DC current of 40 mA is provided through the current loop.

Wave Shape. The square-wave output signal of the calibrator can be used as a reference wave shape when checking or adjusting the compensation of passive, high-resistance probes. Since the square-wave output from the calibrator has a flat top, any distortion in the displayed waveform is due to the probe compensation.

Signal Outputs

+ **Sawtooth.** The + SAWTOOTH connector provides a positive-going sample of the sawtooth signal from the time-base units in the horizontal plug-in compartments. The internal Sweep switch (located behind right side panel; see Fig. 2-8) allows the output sawtooth to be selected from the time-base unit in either the A HORIZ or B HORIZ compartments. Rate of rise of the sawtooth output signal is about 50 millivolts/unit of time into a 50-ohm load, or about one volt/unit of time into a one-megohm load. Unit of time is determined by the time-base time/division switch (e.g., if time/division switch is set to one millisecond/division, a unit of time is one millisecond; at five milliseconds/division, a unit of time is five milliseconds). The peak output voltage is about 500 millivolts into a 50-ohm load or about 10 volts into a one-megohm load.

+ **Gate.** The + GATE output connector provides a positive-going rectangular output pulse from the time-base

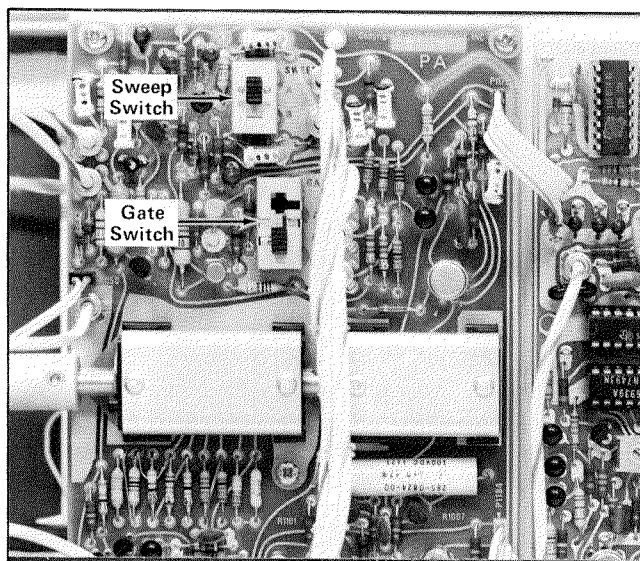

Fig. 2-8. Location of Sweep and Gate switches (behind right side panel).

units in the horizontal plug-in compartments. The Gate switch (located behind the right side panel; see Fig. 2-8) allows the output signal to be selected from the time-base unit in the A HORIZ compartment, B HORIZ compartment, or the delayed gate from a delaying time-base unit in either horizontal compartment. Duration of the gate output signal is the same as the duration of the respective sweep or, in the case of the delayed gate, it starts at the end of the delay period and lasts until the end of the sweep from the delaying time-base unit. Amplitude of the output signal at the + GATE connector is about 0.5 volt into 50 ohms, or about 10 volts into one megohm.

Vertical Signal. The SIG OUT connector provides a sample of the vertical deflection signal. The source of the output signal at this connector is determined by the B TRIGGER SOURCE switch (notice line connecting SIG OUT connector to B TRIGGER SOURCE switch). In the VERT MODE position of the B TRIGGER SOURCE switch, the output signal is determined by the setting of the VERTICAL MODE switch. The output signal in the LEFT and RIGHT positions of the VERTICAL MODE switch is obtained only from the selected vertical unit. The vertical output signal in the ADD position of the VERTICAL MODE switch is the algebraic sum of the left and right vertical unit signals. In the CHOP position of the VERTICAL MODE switch, the output signal is obtained from the left vertical unit. In the ALT position of the VERTICAL MODE switch, the output signal source is also determined by the setting of the HORIZONTAL MODE switch.

When the HORIZONTAL MODE switch is set to A or B, the output signal at the SIG OUT connector switches between vertical units along with the CRT display. However, when the HORIZONTAL MODE switch is set to ALT

or CHOP, the output signal is obtained from the left vertical unit (except for delayed sweep operation; then the output signal is the same as in the A or B positions). The LEFT VERT and RIGHT VERT positions of the B TRIGGER SOURCE switch provide the vertical output signal only from the selected vertical unit even when it is not selected for display. The output voltage into a 50-ohm load is about 25 millivolts/division of CRT display and about 0.5 volt/division of display into a one-megohm load. The bandwidth of the output signal is determined by the vertical plug-in unit which is used (see Systems Specification given in Section 1).

Probe Power Connectors

The two PROBE POWER connectors on the rear panel of this instrument provide operating power for active probe systems. It is not recommended that these connectors be used as a power source for applications other than the compatible probes or other accessories which are specifically designed for use with this system.

Remote Connector

The nine-terminal connector (J90) on the rear panel of the 7904 provides input for remote operation of the instrument and the associated plug-in units. Table 2-4 lists the function of each terminal of J90. The mating connector for J90 is Tektronix Part No. 134-0049-00 (one mating connector supplied as standard accessory). The methods of obtaining remote single-sweep reset and ready indication are given under Remote Single-Sweep Reset. See Remote Readout for information on remote operation of the Readout System. Notice that there are several blank terminals on J90. These terminals can be used for special remote applications.

TABLE 2-4

Remote Connections

J90 Terminal	Function
A	Remote Single-sweep reset (A and B HORIZ)
B	Chassis ground
C	Remote ready indicator (A HORIZ)
D	Remote ready indicator (B HORIZ)
E	Remote readout lockout
F	Remote single-shot readout
H	No connection
J	No connection
K	No connection

Remote Single-Sweep Reset

Remote single-sweep reset operation can be provided to 7B-series time-base units with compatible features through rear-panel connector J90. The remote single-sweep reset actuation can be obtained from either an active system (pulse generator, logic circuit, etc.) or a passive system (switch or relay). Requirements for remote single-sweep reset operation are:

REMOTE SINGLE-SWEEP RESET (A and B HORIZ)

Pin of J90	A
Signal required	Closure to ground (within -5 to $+0.5$ volts) from a positive level.
Maximum current required	10 milliamperes.
Minimum pulse width	10 microseconds at 50% amplitude points.
Maximum input voltage	15 volts (DC + peak AC).

A HORIZ REMOTE READY INDICATOR

Pin of J90	C
Output signal	Open or ground when not ready; $+5$ volts at 47-ohm source impedance when ready. Output sufficient to light a No. 49 bulb.

B HORIZ READY INDICATOR

Pin of J90	D
Output signal	Open or ground when not ready; $+5$ volts at 47-ohm source impedance when ready. Output sufficient to light a No. 49 bulb.

Fig. 2-9 shows a typical passive system to provide remote single-sweep reset operation. The remote ready lights are optional and can be used with an active or passive system whenever it is necessary to provide an indication at the remote location that reset has occurred.

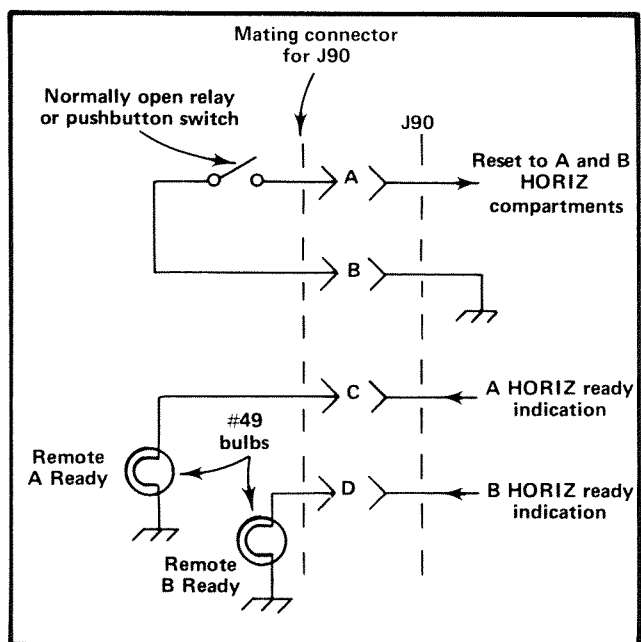

Fig. 2-9. Typical circuit for remote single-sweep reset operation.

Applications

The 7904 Oscilloscope and its associated plug-in units provide a very flexible measurement system. The capabilities of the overall system depend mainly upon the plug-ins that are chosen for use with this instrument. Specific applications for the individual plug-in units are described in the plug-in unit manuals. The overall system can also be used for many applications which are not described in detail, either in this manual or in the manuals for the individual plug-in units. Contact your local Tektronix Field Office or representative for assistance in making specific measurements with this instrument.

The following books describe oscilloscope measurement techniques which can be adapted for use with this instrument.

Harley Carter, "An Introduction to the Cathode Ray Oscilloscope", Philips Technical Library, Cleaver-Hume Press Ltd., London, 1960.

J. Czech, "Oscilloscope Measuring Techniques", Philips Technical Library, Springer-Verlag, New York, 1965.

Robert G. Middleton, "Scope Waveform Analysis", Howard W. Sams & Co. Inc., The Bobbs-Merrill Company Inc., Indianapolis, 1963.

Robert G. Middleton and L. Donald Payne, "Using the Oscilloscope in Industrial Electronics", Howard W. Sams & Co. Inc., The Bobbs-Merrill Company Inc., Indianapolis, 1961.

John F. Rider and Seymour D. Uslan, "Encyclopedia of Cathode-Ray Oscilloscopes and Their Uses", John F. Rider Publisher Inc., New York, 1959.

John F. Rider, "Obtaining and Interpreting Test Scope Traces", John F. Rider Publisher Inc., New York, 1959.

Rufus P. Turner, "Practical Oscilloscope Handbook", Volumes 1 and 2, John F. Rider Publisher Inc., New York, 1964.

MANUAL CHANGE INFORMATION

At Tektronix, we continually strive to keep up with latest electronic developments by adding circuit and component improvements to our instruments as soon as they are developed and tested.

Sometimes, due to printing and shipping requirements, we can't get these changes immediately into printed manuals. Hence, your manual may contain new change information on following pages.

A single change may affect several sections. Sections of the manual are often printed at different times, so some of the information on the change pages may already be in your manual. Since the change information sheets are carried in the manual until ALL changes are permanently entered, some duplication may occur. If no such change pages appear in this section, your manual is correct as printed.

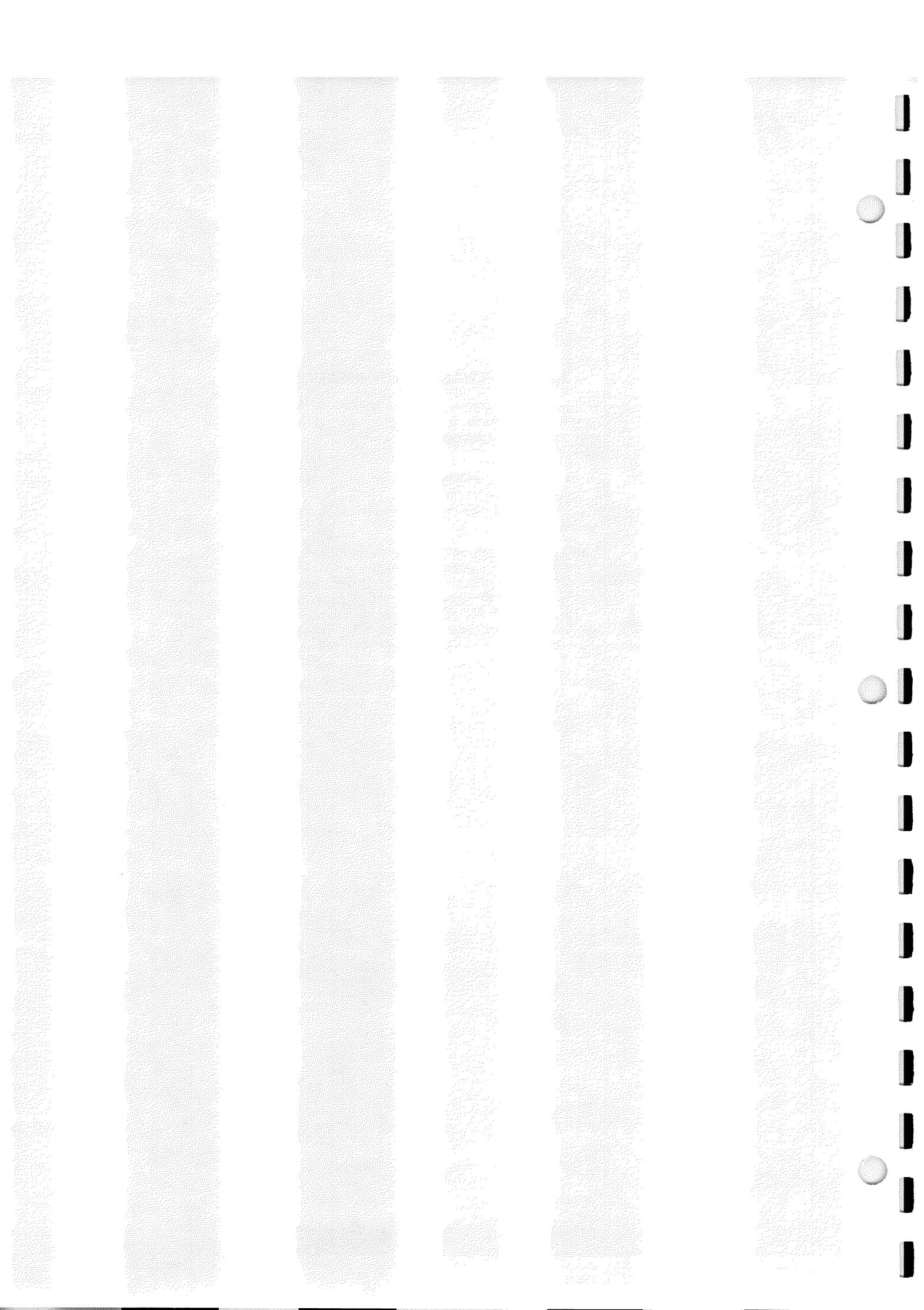

7503
7504
7514
7603/R7603
7613/R7613
7704
R7704
7704A
R7903
7904

Option 3 EMI Modification or EMI Conversion Kit
Installed
(Operators or Instruction Manuals)

SPECIFICATION SECTION

ADD TO: Existing information concerning Option 3:

Any unused plug-in compartments must also be covered with an EMI shielded blank plug-in panel in order to meet the EMI interference specifications. Order or use Tektronix Part No. 016-0155-00 only. One is required for each unused compartment. This applies whether the mainframe was ordered as an Option 3 or modified with the appropriate EMI Conversion Kit.

OPERATING INSTRUCTIONS SECTION

ADD TO: Existing information concerning Plug-In units, Installation:

All of the plug-in compartments do not have to be filled to operate the instrument; the only plug-ins needed are those required for the measurement to be made. At environmental extremes, excess interference may be radiated into or out of the instrument through the plug-in compartments. To reduce such interference, or to meet EMI specifications on factory equipped Option 3 or field EMI modified instruments, all unused plug-in compartments must be covered with an EMI shielded blank plug-in panel. Order or use only Tektronix Part No. 016-0155-00. One is required for each unused compartment.

Service or Instruction Manual

MECHANICAL PARTS LIST

INSTRUMENT OPTIONS

ADD TO: OPTION 3

OPTIONAL ACCESSORIES

016-0155-00

1 PLUG-IN, PANEL, Blank, EMI Shielded
(not shown)

